



STANDARD DETAIL SET

Hurricane



2020

FORTIFIED Home™ - Standard Details Table of Contents

For Use with 2020 FORTIFIED Home Standard

<u>Detail Number</u>	<u>Detail Title</u>	Applicable Levels		
		Roof	Silver	Gold
F-G-1	Corrosion Protection Requirements	✓	✓	✓
F-G-2	Roof and Wall Zone Diagram	✓	✓	✓
F-RS-1	Roof Deck Attachment - Sawn Lumber or Wood Board Roof Deck with No Gaps	✓	✓	✓
F-RS-2	Hurricane - New Construction Roof Deck Attachment - Structural Wood Panels	✓	✓	✓
F-SRD-1	Roof Deck Attachment and Sealed Roof Deck from Within Using Spray Foam	✓	✓	✓
F-SRD-2	Steep Slope Sealed Roof Deck - Flashing Tape and Underlayment- Shingle or Metal Roof Covers	✓	✓	✓
F-SRD-3	Steep Slope Sealed Roof Deck - Two Layers Felt Underlayment - Shingle or Metal Roof Covers	✓	✓	✓
F-SRD-4	Steep Slope Sealed Roof Deck - Self-Adhered Membrane (Showing Bond Break for Asphalt Shingles) - Shingle and Metal Roof Covers	✓	✓	✓
F-SRD-5	Steep Slope Sealed Roof Deck - Flashing Tape, Underlayment and Roof Tile Cap Sheet - Concrete and Clay Tile Roof Covers	✓	✓	✓
F-SRD-6	Steep Slope Sealed Roof Deck - Self-Adhered Membrane - Concrete and Clay Tile Roof Covers	✓	✓	✓
F-SRD-7	Steep Slope Sealed Roof Deck - Two Layers Synthetic Underlayment - 40' and 48" wide Rolls - Shingle or Metal Roof Covers	✓	✓	✓
F-SRD-8	Steep Slope Sealed Roof Deck - Two Layers Synthetic Underlayment - 60" wide Rolls - Shingle or Metal Roof Covers	✓	✓	✓
F-DE-1	Hurricane - Drip Edge Installation Over Underlayment	✓	✓	✓
F-DE-2	DISCONTINUED IN 2020	N/A	N/A	N/A
F-RC-1	Asphalt Shingle Installation Guidance for Steep Slope - Option 1: Peel and Stick Starter Strip Installation at Eave or Rake	✓	✓	✓
F-RC-2	Asphalt Shingle Installation Guidance for Steep Slope - Option 2: Shingle Strip Starter Installation at Eave or Rake	✓	✓	✓
F-RC-3	Asphalt Shingle Installation Guidance for Steep Slope - Option 3: Shingles Set Directly in Flashing Cement at Rake Only	✓	✓	✓
F-RR-1	Re-Roofing Deck Replacement Fastening Detail	✓	✓	✓
F-RR-2	Re-Roofing New Scab Member Detail for Damaged or Deteriorated Wood Framing Member	✓	✓	✓
F-RR-3	Hurricane - Re-Nailing the Roof Deck (Wood Structural Panels)	✓	✓	✓
F-RR-5	Fastening Wood Structural Panel Roof Sheathing Over Existing 1x Roo Deck Boards with Gaps	✓	✓	✓
F-GS-1	Temporary Gable Vent Shuttering	✓	✓	✓
F-GE-1	Prescriptive Gable End Outlooker Framing and Anchorage	N/A	✓	✓
F-S-1	Soffit Retrofit Detail	N/A	✓	✓
F-CTD-1	Prescriptive Chimney Tie-Down Detail for Chimneys up to 5 ft	N/A	✓	✓

FORTIFIED Home™ Standard Details Naming Convention

FORTIFIED Home™ Standard Detail numbers are comprised of three alphanumeric identifications to provide general categorization:

1. First alphabetic identification – FORTIFIED Detail:
 - F = FORTIFIED

2. Second alphabetic identification – Secondary Category
 - G = General Information
 - RS = Roof Sheathing
 - SRD = Sealed Roof Deck
 - DE = Drip Edge
 - RC = Roof Cover
 - RR = Re-Roof
 - GS = Gable Shuttering
 - GE = Gable End
 - S = Soffit
 - CTD = Chimney Tie Down

3. Numeric identification – chronological order detail was completed

Example: F-RS-1

Fortified Detail → Roof Sheathing Detail → First Detail in this category



FORTIFIED Home™

Corrosion Protection Requirements for Fasteners & Connectors in Coastal Regions

For all connections described in this table: if corrosion is observed at time of re-designation, designation may not be renewed.

Requirements & Best Practices for FORTIFIED Roof™ Designations			
	REQUIREMENTS		BEST PRACTICES
	<i>Distance to saltwater shoreline¹</i>		<i>Distance to brackish water shoreline</i>
ROOF CONNECTIONS	0-300 ft	300-3000 ft	0-300 ft
Roofing nails for shingles	Category A	Category B (or better)	Category B (or better)
Concrete and clay roof tile fasteners			
Roof vent fasteners	Follow manufacturer's corrosion resistance guidance for coastal areas. If not provided by manufacturer, the following corrosion resistance categories may be accepted for exposed fasteners and clips		
Metal roof system including panels and exposed fasteners, clips, etc.			
Fasteners used for attachment of underlayment to roof deck			
Roof-mounted equipment exposed connections and fasteners	Category A	Category B (or better)	

Requirements and Best Practices for FORTIFIED Silver™ and FORTIFIED Gold™ Designations			
	REQUIREMENTS		BEST PRACTICES
	<i>Distance to saltwater shoreline¹</i>		<i>Distance to brackish water shoreline</i>
EXTERIOR EXPOSED CONNECTIONS (including under soffits and elevated foundations)	0-300 ft	300-3000 ft	0-300 ft
Silver:	Category A	Category B (or better)	Category B (or better)
<ul style="list-style-type: none"> Soffit fasteners Exposed attached structure connectors, anchors, fasteners 			
Gold: Exposed CLP connectors, anchors, fasteners	<i>Aluminum Soffits NOT Allowed</i>	<i>Aluminum Soffits Allowed</i>	

	BEST PRACTICES		BEST PRACTICES
	<i>Distance to saltwater shoreline¹</i>		<i>Distance to brackish water shoreline</i>
INTERIOR CONNECTIONS (including enclosed in attic or within wall cavity)	0-300 ft	300-3000 ft	0-300 ft
Silver:	Category B (or better)		Category C (or better)
<ul style="list-style-type: none"> Gable bracing metal connectors and fasteners Gable outlooker hangers, clips and fasteners Chimney framing metal connectors and fasteners 			
Gold: Enclosed CLP connectors, anchors, fasteners			

Corrosion Resistance Categories ^{2,3}	
CATEGORY A - STAINLESS STEEL OR EQUIVALENT	CATEGORY B - ENHANCED GALVANIZED OR EQUIVALENT
<u>Metal connectors:</u> <ul style="list-style-type: none"> Stainless steel per ASTM A316 <u>Fasteners:</u> <ul style="list-style-type: none"> Stainless steel per ASTM A304 or A316 Proprietary coated fasteners require documentation of equivalent corrosion protection performance to stainless steel, such as equivalence testing per ICC-ES AC257 Exposure Condition 4, or other comparative testing documentation 	<u>Metal connectors:</u> <ul style="list-style-type: none"> Galvanized per ASTM A653 with G185 coating Hot-dip galvanized per ASTM A123 <u>Fasteners with diameters over 3/8 in.:</u> <ul style="list-style-type: none"> Hot-dip galvanized per ASTM A153 Class C <u>Fasteners with diameters up to 3/8 in. shall meet one of the following:</u> <ul style="list-style-type: none"> Hot-dip galvanized per ASTM A153 Class D Galvanized per ASTM A641 Class 3 Per ASTM G85, Annex 5, Corrosion resistance exhibiting not more than 5% red rust after the following: <ul style="list-style-type: none"> for nails: 280 hours for roof tile fasteners: 1000 hours for other carbon steel fasteners: 360 hours In lieu of testing listed above, proprietary coated fasteners require documentation of equivalent or superior corrosion protection performance to the galvanization options listed above, such as equivalence testing per ICC-ES AC257 Exposure Condition 4, or other comparative testing documentation Testing per ASTM B117 with corrosion resistance exhibiting not more than 5% red rust after 1,000 hours exposure may be accepted if no other testing is available
CATEGORY C - STANDARD GALVANIZED	
<u>Metal connectors:</u> <ul style="list-style-type: none"> Galvanized per ASTM A653 with G90 coating <u>Fasteners:</u> <ul style="list-style-type: none"> Galvanized per ASTM A641 Class 1 	

NOTES	
1. For the purposes of FORTIFIED Home designation, "saltwater shoreline" shall be considered as the ocean or gulf coastline along the mainland United States including seaward island coastlines. This includes the Atlantic, Pacific, and Gulf of Mexico coastlines, as well as the coastline of any Bay or Sound with no land barrier separating it from being completely open to the ocean or Gulf of Mexico. Distances are measured from the closest feature of the subject building to the ocean or gulf coastline.	
2. Fastener and connector materials and coatings must be compatible with materials and coatings they come into contact with to prevent galvanic corrosion due to dissimilar materials.	
3. Fasteners in contact with chemically treated wood shall be in accordance with the requirements of the IBC/IRC or locally adopted code as applicable.	

APPLICABLE STANDARDS:

FORTIFIED HOME™ - HURRICANE (2020)
 FORTIFIED HOME™ - HIGH WIND (2020)

DESCRIPTION:

CORROSION PROTECTION REQUIREMENTS

DRAWING #:

F-G-1

DATE:

11/01/2021

INTERIOR ZONES
ROOFS - ZONE 1/ WALLS - ZONE 4

END ZONES
ROOFS - ZONE 2/ WALLS - ZONE 5

CORNER ZONES
ROOFS - ZONE 3

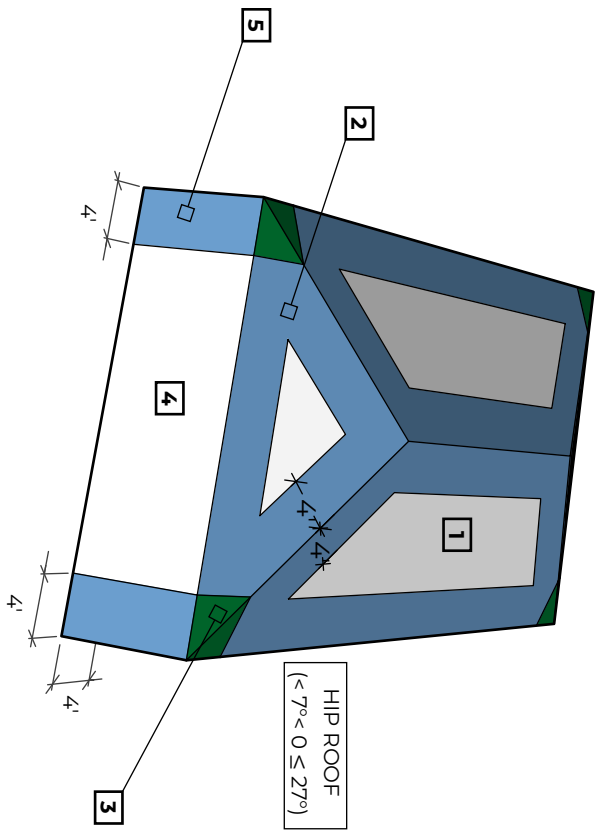
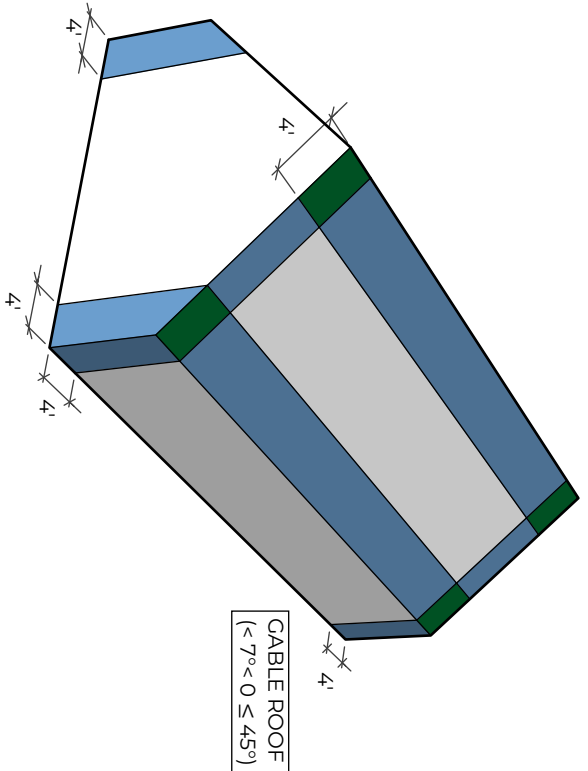
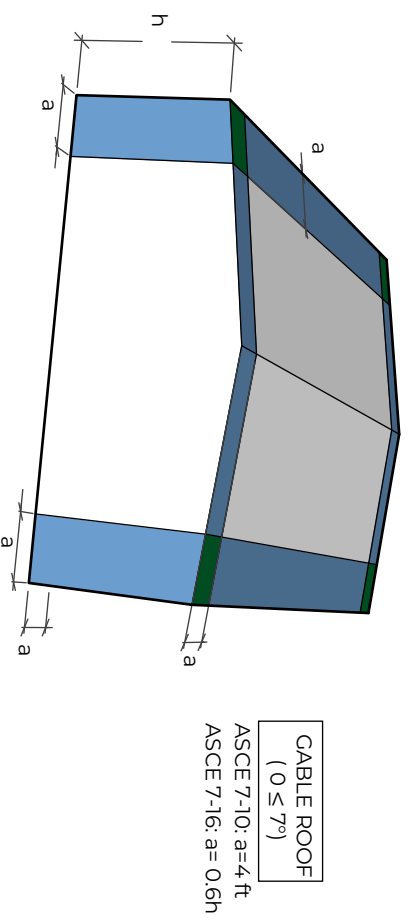
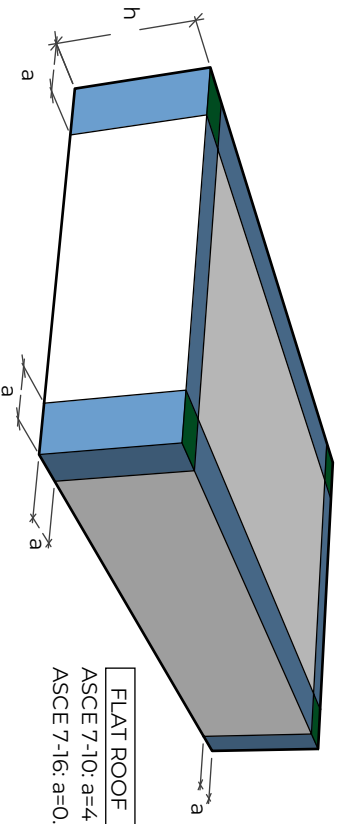

- GENERAL NOTES:
1. REFER TO APPLICABLE FORTIFIED HOME STANDARDS FOR ADDITIONAL INFORMATION.
 2. FORTIFIED HOME STANDARDS ARE TO BE APPLIED IN CONJUNCTION WITH FEDERAL, STATE, AND LOCAL CODES, ORDINANCES AND REGULATIONS IN ADDITION TO THE STRUCTURAL DESIGN WHICH IS BY OTHERS. IN CASE OF A CONFLICT BETWEEN PROVISIONS, USE WHICHEVER IS MORE STRINGENT.

APPLICABLE STANDARDS:

FORTIFIED HOME™ - HURRICANE (2020)
FORTIFIED HOME™ - HIGH WIND (2020)

DESCRIPTION:

ROOF AND WALL ZONE DIAGRAM

DRAWING #:

F-G-2

DATE: 11/01/2020



- GENERAL NOTES:**
1. REFER TO APPLICABLE FORTIFIED HOME STANDARDS FOR ADDITIONAL INFORMATION.
 2. APPLICABLE FOR SHINGLE OR METAL ROOF COVERS.
 3. FORTIFIED HOME STANDARDS ARE TO BE APPLIED IN CONJUNCTION WITH FEDERAL, STATE, AND LOCAL CODES, ORDINANCES AND REGULATIONS IN ADDITION TO THE STRUCTURAL DESIGN WHICH IS BY OTHERS. IN CASE OF A CONFLICT BETWEEN PROVISIONS, USE WHICHEVER IS MORE STRINGENT.

REFER TO TABLE F-RS-1 FOR REQUIRED SIZE AND NUMBER OF NAILS.

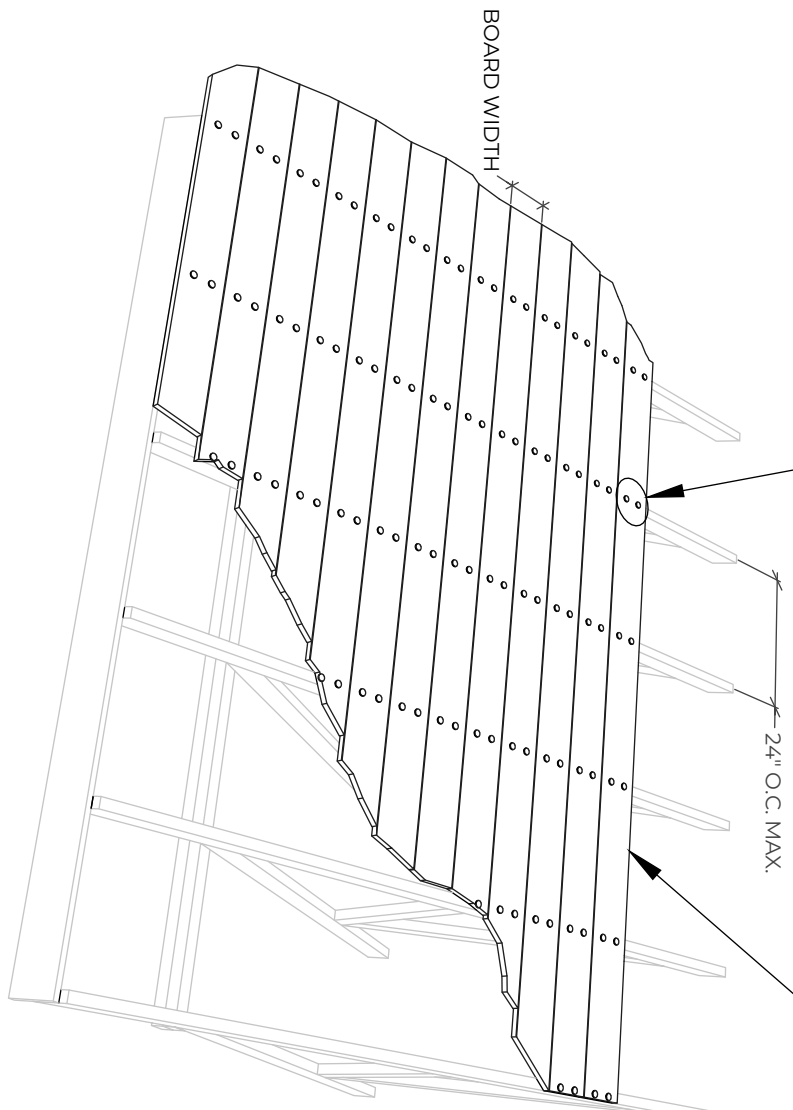

MINIMUM 5/8" SAWN LUMBER OR WOOD BOARD ROOF DECK BY OTHERS.

ROOF FRAMING MEMBERS W/ 2" MIN. NOMINAL THICKNESS.

Table F-RS-1: FASTENERS REQUIRED FOR WOOD BOARD DECKING ATTACHMENT.

WOOD BOARD/LUMBER (ROOF DECKING) WIDTH	NUMBER AND MINIMUM DIMENSIONS OF NAILS PER BOARD FOR EACH FRAMING MEMBER IT CROSSES
UP TO 8"	TWO(2) 0.131" Ø MIN. W/ 1 - 5/8" PENETRATION INTO ROOF FRAMING MEMBERS (MIN. LENGTH OF NAIL= 2 - 1/2")
LARGER THAN 8"	THREE(3) 0.131" Ø MIN. W/ 1 - 5/8" PENETRATION INTO ROOF FRAMING MEMBERS (MIN. LENGTH OF NAIL= 2 - 1/2")

NOTE: CLIPPED-HEAD, D-HEAD, OR ROUND-HEAD NAILS SHALL BE ACCEPTABLE PROVIDED THEY HAVE THE REQUIRED MINIMUM DIAMETER AND LENGTH.

APPLICABLE STANDARDS:

FORTIFIED HOME™ - HURRICANE (2020)
 FORTIFIED HOME™ - HIGH WIND (2020)

DESCRIPTION:

ROOF DECK ATTACHMENT - SAWN LUMBER OR WOOD BOARD ROOF DECK WITH NO GAPS

DRAWING #:

F-RS-1

DATE:

11/01/2020



GENERAL NOTES:

1. REFER TO APPLICABLE FORTIFIED HOME STANDARDS FOR ADDITIONAL INFORMATION. FORTIFIED HOME STANDARDS ARE TO BE APPLIED IN CONJUNCTION WITH FEDERAL, STATE, AND LOCAL CODES, ORDINANCES AND REGULATIONS IN ADDITION TO THE STRUCTURAL DESIGN WHICH IS BY OTHERS. IN CASE OF A CONFLICT BETWEEN PROVISIONS, USE WHICHEVER IS MORE STRINGENT.
- 2.

Table F-RS-2: MINIMUM REQUIREMENTS FOR ROOF SHEATHING THICKNESS AND FASTENING

ASCE Edition	Minimum Roof Sheathing Thickness ^{1,2,3}	Minimum Nail Size/Type ^{1,4}	Maximum Nail Spacing (All Roof Areas) ¹
ASCE 7-10	7/16"	See Notes 1, 2, 3	RSRS-01; 0.113" dia. x 2-3/8" Roof Sheathing Ring Shank Nail
ASCE 7-16	15/32"	See Notes 1, 3	4" O.C.

Notes:

1. Local building code requirements for roof sheathing thickness and/or nail size/attachment spacing may be more stringent based on site conditions.
2. For concrete and clay tile roof covers, minimum required sheathing thickness is 15/32".
3. For metal roof covers, verify manufacturer's sheathing thickness requirements are met.
4. Full round head ϕ ; No clipped-head nails, common nails or staples shall be allowed. Refer to Figure 1.

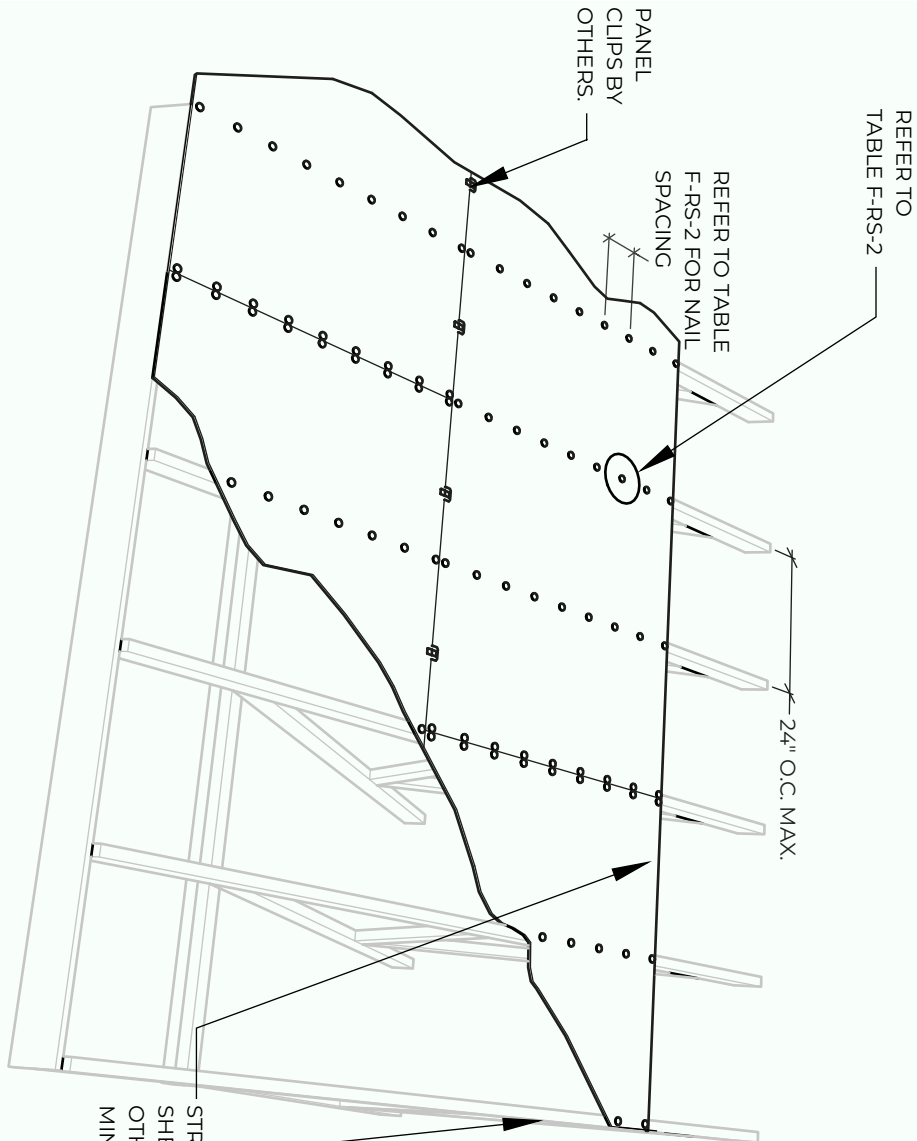

ROOF FRAMING MEMBERS W/ 2" MIN. NOMINAL THICKNESS.
STRUCTURAL WOOD PANEL ROOF SHEATHING (PLYWOOD OR OSB) BY OTHERS. REFER TO TABLE F-RS-2 FOR MINIMUM THICKNESS REQUIREMENTS.

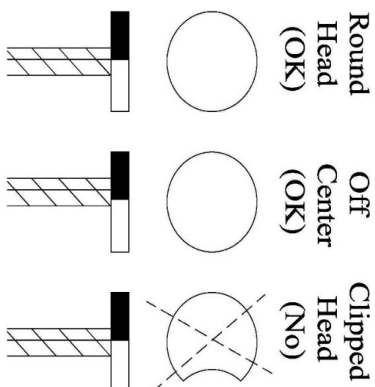

FIGURE 1.

APPLICABLE STANDARDS:

FORTIFIED HOME™ - HURRICANE (2020)

DESCRIPTION:

HURRICANE - NEW CONSTRUCTION
ROOF DECK ATTACHMENT -
STRUCTURAL WOOD PANELS

DRAWING #:

F-RS-2

DATE:

11/01/2020



1. MINIMUM REQUIREMENTS FOR SPRAY ADHESIVES:
PRODUCT MUST BE TESTED AND EVALUATED IN ACCORDANCE WITH EITHER ASTM E530, STANDARD TEST METHOD FOR STRUCTURAL PERFORMANCE OF EXTERIOR WINDOWS, DOORS, SKYLIGHTS, AND CURTAIN WALLS BY UNIFORM STATIC AIR PRESSURE DIFFERENCE (APPLIED TO ROOF SHEATHING) OR TAS 202-94, CRITERIA FOR TESTING IMPACT AND NON-IMPACT RESISTANT BUILDING ENVELOPE COMPONENTS USING UNIFORM STATIC AIR PRESSURE. THE MINIMUM ALLOWABLE DESIGN UPLIFT PRESSURE MUST BE GREATER THAN OR EQUAL TO 110 PSF AND THE PROOF TEST PRESSURE ACHIEVED WITHOUT FAILURE OR STRUCTURAL DISTRESS MUST BE GREATER THAN OR EQUAL TO 165 PSF.
2. ADHESIVE MUST BE A TWO-COMPONENT SPRAY POLYURETHANE FOAM SYSTEM WITH A MINIMUM CORE DENSITY OF 1.5-3.0 PCF IN ACCORDANCE WITH ASTM D1622, STANDARD TEST METHOD FOR APPARENT DENSITY OF RIGID CELLULAR PLASTICS.
3. SPRAY POLYURETHANE FOAM ADHESIVE SYSTEM MUST BE INSTALLED BY A PROPERLY TRAINED AND QUALIFIED APPLICATOR IN ACCORDANCE WITH THE MANUFACTURERS MAINTENANCE AND INSTALLATION GUIDELINES. DOCUMENTATION FROM THE INSTALLING CONTRACTOR, ON COMPANY LETTERHEAD, IDENTIFYING THE MANUFACTURER AND PRODUCT USED FOR THE IMPROVED ROOF SHEATHING ATTACHMENT/SEALED ROOF DECK MUST BE PROVIDED TO THE CERTIFIED FORTIFIED EVALUATOR TO BE INCLUDED WITH FINAL DESIGNATION CHECKLIST. DOCUMENTATION SHOULD ALSO STATE THAT THE INSTALLATION MEETS THE MANUFACTURERS REQUIREMENTS FOR AN ALLOWABLE DESIGN UPLIFT PRESSURE OF AT LEAST 110 PSF (PROOF TEST OF AT LEAST 165 PSF).
5. **USE THE MINIMUM DENSITY AND INSTALLATION REQUIREMENTS PRESCRIBED BY THE MANUFACTURER TO MEET A MINIMUM DESIGN UPLIFT PRESSURE ON THE SHEATHING OF 110 PSF FOR HURRICANE OR 80 PSF FOR HIGH WIND.**

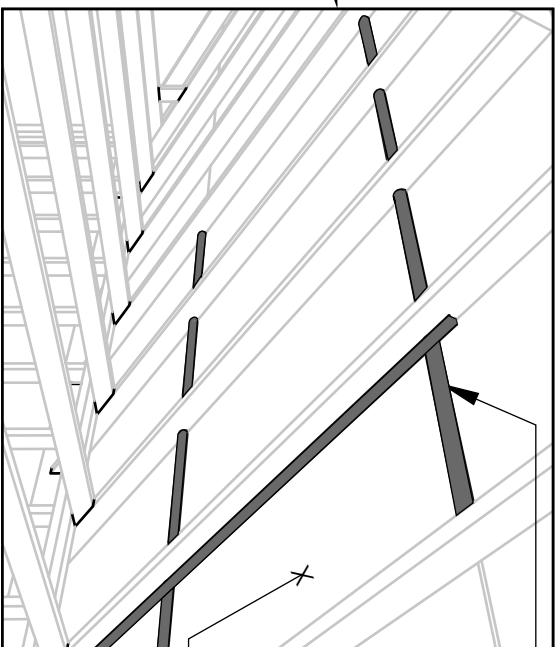
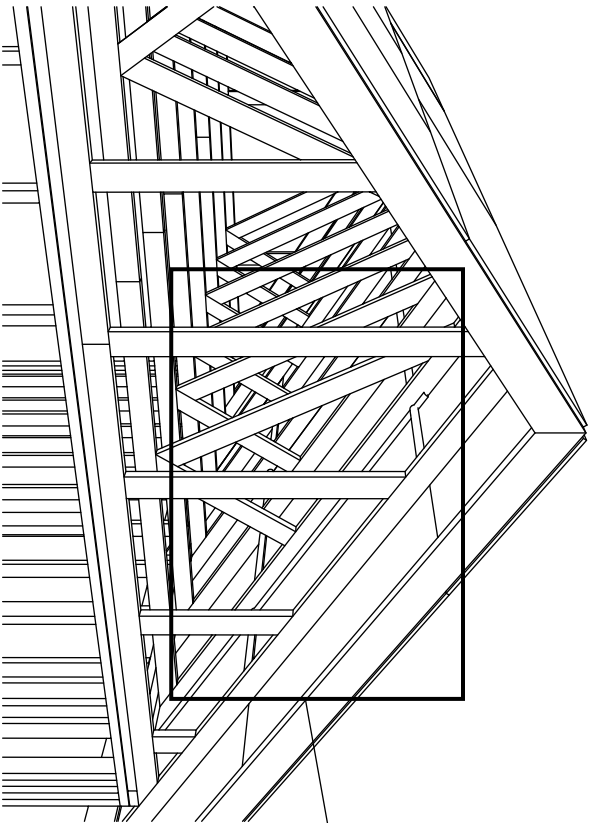

UNDERSIDE OF ROOF DECK FROM WITHIN ATTIC

GENERAL NOTES:
REFER TO APPLICABLE FORTIFIED HOME STANDARDS FOR ADDITIONAL INFORMATION. EXISTING SHEATHING REQUIREMENTS: FOR HURRICANE: 7/16" MIN. THICKNESS REQUIRED WITH ROOF MEMBERS @ 24" O.C. MAX.
FOR HIGH WIND: 7/16" MIN. THICKNESS IS REQUIRED FOR GOLD DESIGNATION. FOR ROOF/SILVER DESIGNATION, 3/8" MIN. THICKNESS IS PERMITTED WHEN ROOF MEMBERS ARE 16" O.C. MAX.
FORTIFIED HOME STANDARDS ARE TO BE APPLIED IN CONJUNCTION WITH FEDERAL, STATE, AND LOCAL CODES, ORDINANCES AND REGULATIONS IN ADDITION TO THE STRUCTURAL DESIGN WHICH IS BY OTHERS. IN CASE OF A CONFLICT BETWEEN PROVISIONS, USE WHICHEVER IS MORE STRINGENT.

1 1/2" TO 3" FILLET OF 2-PART SPRAY-APPLIED CLOSED CELL POLYURETHANE FOAM ADHESIVE AT ALL JOINTS BETWEEN SHEATHING AND AT ALL INTERSECTIONS BETWEEN ROOF SHEATHING AND ROOF FRAMING MEMBERS, AND AT ALL VALLEYS. REFER TO MINIMUM REQUIREMENTS FOR SPRAY ADHESIVES.
EXISTING STRUCTURAL WOOD PANEL ROOF SHEATHING BY OTHERS. REFER TO GENERAL NOTE #2 FOR REQUIREMENTS.

APPLICABLE STANDARDS:

FORTIFIED HOME™ - HURRICANE (2020)
FORTIFIED HOME™ - HIGH WIND (2020)

DESCRIPTION:

STEEP SLOPE ROOF DECK ATTACHMENT AND SEALED ROOF DECK FROM WITHIN USING SPRAY FOAM

DRAWING #:

F-SRD-1

DATE:

11/01/2020



GENERAL NOTES:

1. REFER TO APPLICABLE FORTIFIED HOME STANDARDS FOR ADDITIONAL INFORMATION.
2. REFER TO FORTIFIED STANDARD DETAIL F-C-1 FOR CORROSION PROTECTION REQUIREMENTS.
3. APPLICABLE FOR ROOF PITCH 2:12 OR GREATER. NAILS USED TO ATTACH UNDERLAYMENT SHALL BE ANNULAR RING OR DEFORMED SHANK ROOFING NAILS W/ 0.083" MINIMUM DIAMETER AND SUFFICIENT LENGTH TO PENETRATE THROUGH THE ROOF SHEATHING OR NOT LESS THAN 3/4" INTO THE ROOF SHEATHING. W/ 1" DIAMETER BUTTON CAPS (METAL BUTTON CAPS ARE REQUIRED FOR ULTIMATE DESIGN WIND SPEED OF 160 MPH OR GREATER).
5. FORTIFIED HOME STANDARDS ARE TO BE APPLIED IN CONJUNCTION WITH FEDERAL, STATE, AND LOCAL CODES, ORDINANCES AND REGULATIONS IN ADDITION TO THE STRUCTURAL DESIGN WHICH IS BY OTHERS. IN CASE OF A CONFLICT BETWEEN PROVISIONS, USE WHICHEVER IS MORE STRINGENT.

- FLASHING TAPE AT ALL PANEL SEAMS FULLY ADHERED W/ NO WRINKLES OR VOIDS USING ROLLER.
- MATERIAL OPTION 1: 4" WIDE ASTM D1970 COMPLIANT SELF-ADHERING POLYMER - MODIFIED BITUMEN FLASHING TAPE.
- MATERIAL OPTION 2: 3 - 3/4" WIDE AAMA 711-13 LEVEL 3 (FOR EXPOSURE UP TO 80°C/176°F) COMPLIANT SELF-ADHERING FLASHING TAPE.
- ASTM D226 TYPE II #30 OR ASTM D4869 TYPE III OR TYPE IV #30 UNDERLAYMENT. (FOR ASPHALT SHINGLE ROOF COVERS, ASTM D6757 UNDERLAYMENT IS ALSO ACCEPTABLE)
- ALT. REINFORCED SYNTHETIC ROOF UNDERLAYMENT WITH ICC APPROVAL AS ASTM D226 TYPE II:
- MINIMUM TEAR STRENGTH = 15 LBF PER ASTM D4533
- MINIMUM TENSILE STRENGTH = 20 PSF PER ASTM D5035
- PASS ASTM D4869 SHOWER TEST.
- HORIZONTAL LAPS = 4" MIN.
- END LAPS = 6" MIN.
- HOLD BACK BUTTON CAPS AT EDGES TO AVOID INSTALLING DRIP EDGE OVER BUTTON CAPS. REFER TO F-DE-1 AND/OR F-DE-3 FOR DRIP EDGE INSTALLATION.

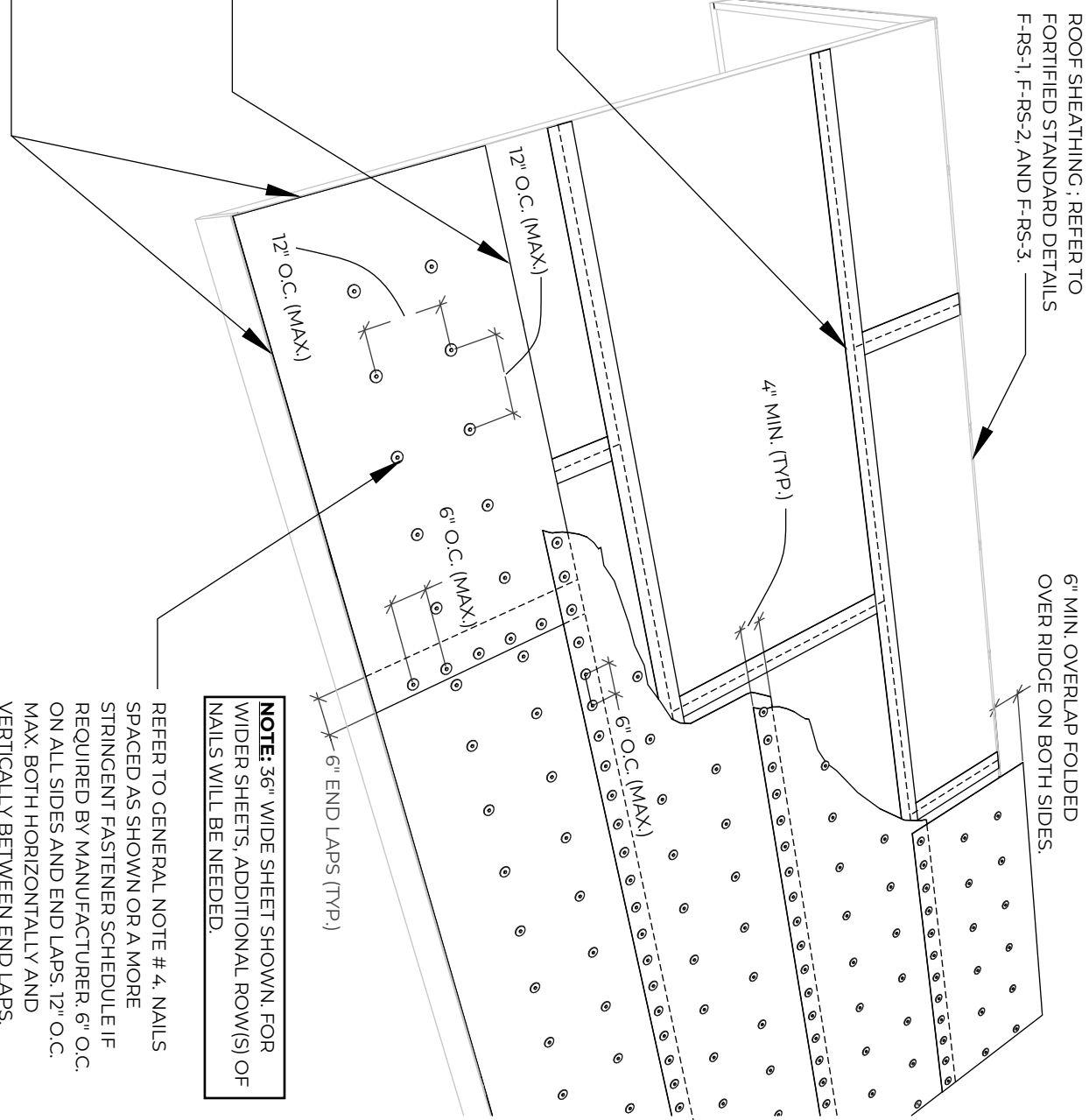

NOTE: 36" WIDE SHEET SHOWN. FOR WIDER SHEETS, ADDITIONAL ROW(S) OF NAILS WILL BE NEEDED.

REFER TO GENERAL NOTE # 4. NAILS SPACED AS SHOWN OR A MORE STRINGENT FASTENER SCHEDULE IF REQUIRED BY MANUFACTURER. 6" O.C. ON ALL SIDES AND END LAPS. 12" O.C. MAX. BOTH HORIZONTALLY AND VERTICALLY BETWEEN END LAPS.

APPLICABLE STANDARDS:

FORTIFIED HOME™ - HURRICANE (2020)
 FORTIFIED HOME™ - HIGH WIND (2020)

DESCRIPTION:

STEEP SLOPE SEALED ROOF DECK -
 FLASHING TAPE AND UNDERLAYMENT -
 SHINGLE OR METAL ROOF COVERS

DRAWING #:

F-SRD-2

DATE:

11/01/2020



GENERAL NOTES:

1. REFER TO APPLICABLE FORTIFIED HOME STANDARDS FOR ADDITIONAL INFORMATION.
2. REFER TO FORTIFIED STANDARD DETAIL F-G-1 FOR CORROSION PROTECTION REQUIREMENTS.
3. WEAVE UNDERLAYMENT ACROSS VALLEYS.
4. DOUBLE LAP UNDERLAYMENT ACROSS RIDGES (UNLESS THERE IS A CONTINUOUS RIDGE VENT).
5. LAP UNDERLAYMENT WITH MINIMUM 6" LEG. TURNED UP" AT WALL INTERSECTIONS; LAP WALL WEATHER BARRIER OVER TURNED-UP ROOF UNDERLAYMENT.
6. APPLICABLE FOR ROOF PITCH 2:12 OR GREATER.
7. NAILS USED TO ATTACH UNDERLAYMENT SHALL BE ANNULAR RING OR DEFORMED SHANK ROOFING NAILS W/ 0.083" MINIMUM DIAMETER AND SUFFICIENT LENGTH TO PENETRATE THROUGH THE ROOF SHEATHING OR NOT LESS THAN 3/4" INTO THE ROOF SHEATHING W/ 1" DIAMETER BUTTON CAPS (METAL BUTTON CAPS ARE REQUIRED FOR ULTIMATE DESIGN WIND SPEED OF 160 MPH OR GREATER.)
8. FORTIFIED HOME STANDARDS ARE TO BE APPLIED IN CONJUNCTION WITH FEDERAL, STATE, AND LOCAL CODES, ORDINANCES AND REGULATIONS IN ADDITION TO THE STRUCTURAL DESIGN WHICH IS BY OTHERS. IN CASE OF A CONFLICT BETWEEN PROVISIONS, USE WHICHEVER IS MORE STRINGENT.

ROOF SHEATHING BY OTHERS; REFER TO FORTIFIED STANDARD DETAILS F-RS-1, F-RS-2, AND F-RS-3.

ASTM D226 TYPE II #30 OR ASTM D4869 TYPE III OR TYPE IV #30 UNDERLAYMENT LAPPED AS SHOWN. (FOR ASPHALT SHINGLE ROOF COVERS, ASTM D6757 UNDERLAYMENT IS ALSO ACCEPTABLE)

6" MIN. OVERLAP FOLDED OVER RIDGE ON BOTH SIDES

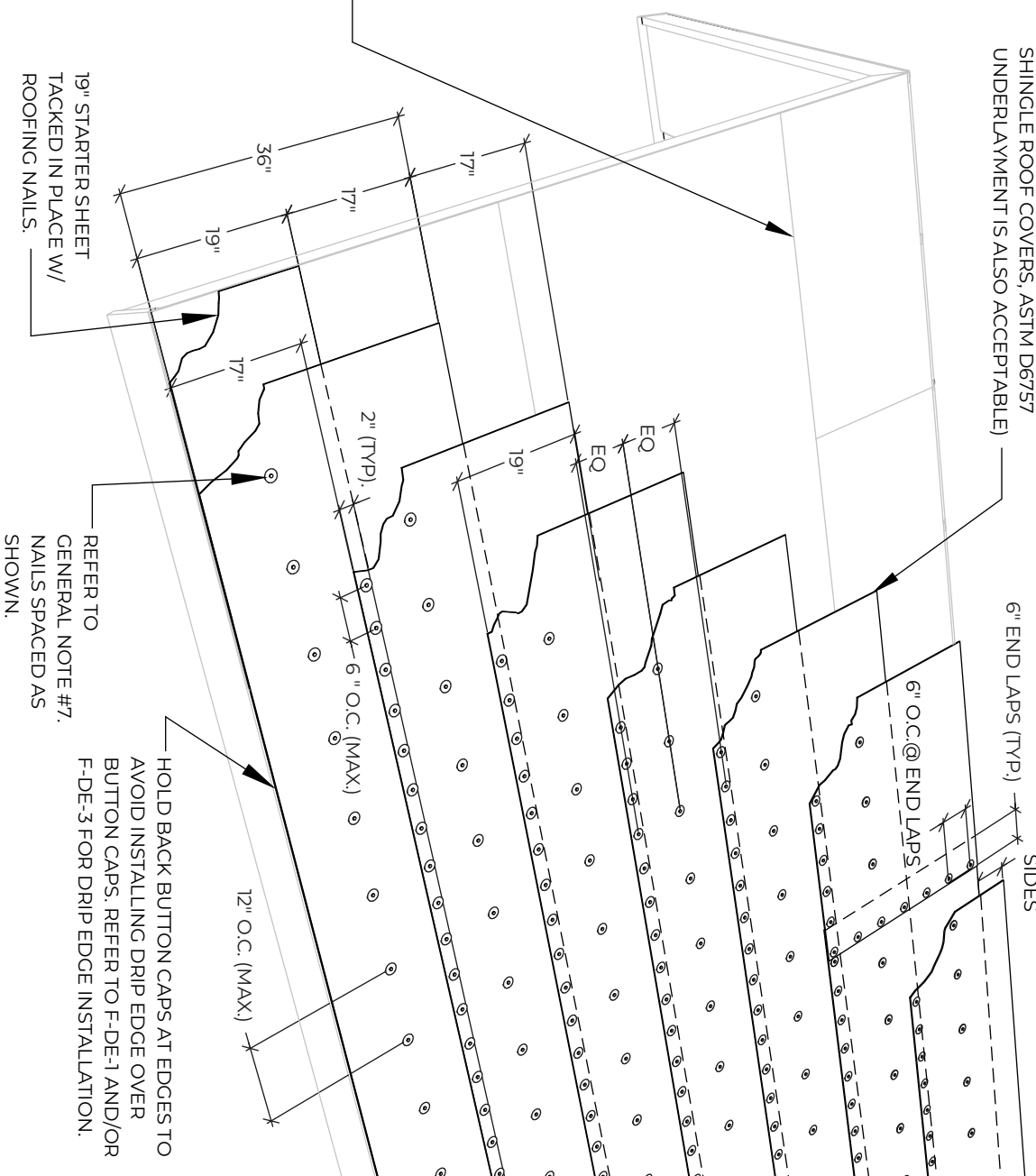

19" STARTER SHEET TACKED IN PLACE W/ ROOFING NAILS.

REFER TO GENERAL NOTE #7. NAILS SPACED AS SHOWN.

HOLD BACK BUTTON CAPS AT EDGES TO AVOID INSTALLING DRIP EDGE OVER BUTTON CAPS. REFER TO F-DE-1 AND/OR F-DE-3 FOR DRIP EDGE INSTALLATION.

APPLICABLE STANDARDS:

FORTIFIED HOME™ - HURRICANE (2020)
FORTIFIED HOME™ - HIGH WIND (2020)

DESCRIPTION:

STEEP SLOPE SEALED ROOF DECK -
TWO LAYERS FELT UNDERLAYMENT -
SHINGLE OR METAL ROOF COVERS

DRAWING #:

F-SRD-3

DATE:

11/01/2020



1. GENERAL NOTES:
2. REFER TO APPLICABLE FORTIFIED HOME STANDARDS FOR ADDITIONAL INFORMATION.
3. APPLICABLE FOR ROOF PITCH 2:12 OR GREATER. REFER TO AND INSTALL IN ACCORDANCE WITH MANUFACTURER SPECIFICATIONS AND INSTALLATION INSTRUCTIONS. REFER TO PRODUCT APPROVAL TO VERIFY REQUIRED WIND PRESSURES ARE MET IF APPLICABLE.
4. ADEQUATE ATTIC VENTILATION IS REQUIRED. REFER TO UNDERLAYMENT AND PRIMARY ROOF SYSTEM MANUFACTURER'S INSTALLATION INSTRUCTIONS FOR VENTILATION LIMITATIONS. ALSO CHECK WITH LOCAL BUILDING CODES FOR RESTRICTIONS.
5. FORTIFIED HOME STANDARDS ARE TO BE APPLIED IN CONJUNCTION WITH FEDERAL, STATE, AND LOCAL CODES, ORDINANCES AND REGULATIONS IN ADDITION TO THE STRUCTURAL DESIGN WHICH IS BY OTHERS. IN CASE OF A CONFLICT BETWEEN PROVISIONS, USE WHICHEVER IS MORE STRINGENT.

ROOF SHEATHING; REFER TO FORTIFIED STANDARD DETAILS F-RS-1, F-RS-2, AND F-RS-3. APPLY MANUFACTURER-SPECIFIED COMPATIBLE PRIMER TO ROOF SHEATHING PER MANUFACTURER INSTALLATION INSTRUCTIONS.

4" MIN. SIDELAPS OR GREATER IF SPECIFIED BY MANUFACTURER'S SPECIFICATIONS AND INSTALLATION INSTRUCTIONS.

REFER TO F-DE-1 AND/OR F-DE-3 FOR DRIP EDGE INSTALLATION.

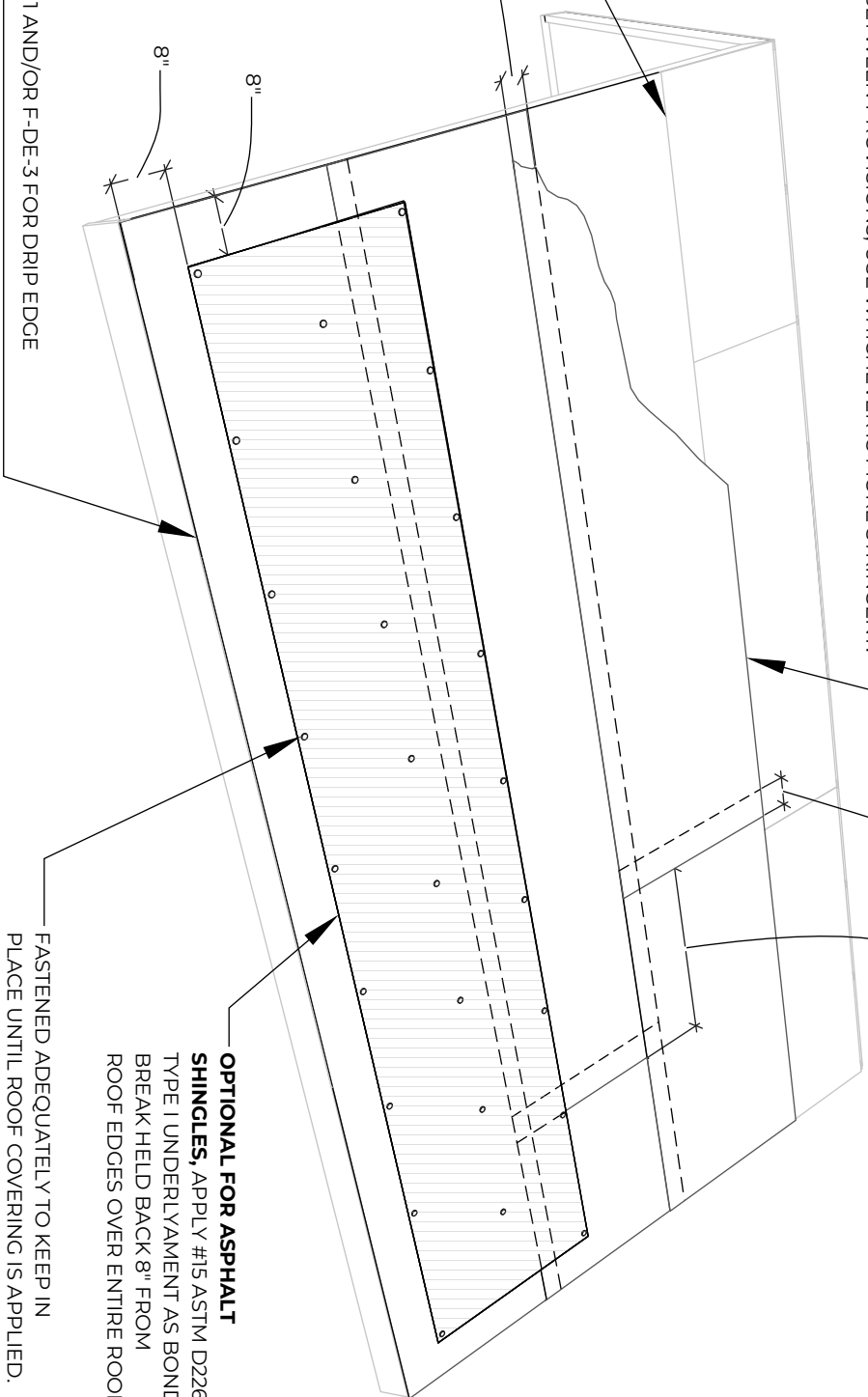

ASTM D1970 SELF-ADHERING POLYMER-MODIFIED BITUMEN MEMBRANE COVERING ENTIRE ROOF DECK. REFER TO GENERAL NOTES #3 AND #4.

REFER TO MANUFACTURER'S SPECIFICATIONS FOR REQUIRED OVERLAP AND FOLLOW INSTALLATION INSTRUCTIONS.

STAGGER AND INSTALL END LAPS AS SPECIFIED PER MANUFACTURER'S SPECIFICATIONS AND INSTALLATION INSTRUCTIONS.

FASTENED ADEQUATELY TO KEEP IN PLACE UNTIL ROOF COVERING IS APPLIED.

OPTIONAL FOR ASPHALT SHINGLES, APPLY #15 ASTM D226 TYPE I UNDERLAYMENT AS BOND BREAK HELD BACK 8" FROM ROOF EDGES OVER ENTIRE ROOF.

APPLICABLE STANDARDS:

FORTIFIED HOME™ - HURRICANE (2020)
FORTIFIED HOME™ - HIGH WIND (2020)

DESCRIPTION:

STEEP SLOPE SEALED ROOF DECK - SELF-ADHERED MEMBRANE (SHOWING BOND BREAK FOR ASPHALT SHINGLES) - SHINGLE AND METAL ROOF COVERS

DRAWING #:

F-SRD-4

DATE:

11/01/2020



GENERAL NOTES:

1. REFER TO APPLICABLE FORTIFIED HOME STANDARDS FOR ADDITIONAL INFORMATION.
2. REFER TO FORTIFIED STANDARD DETAIL F-C-1 FOR CORROSION PROTECTION REQUIREMENTS.
3. APPLICABLE FOR ROOF PITCH 2:12 OR GREATER. REFER TO AND INSTALL IN ACCORDANCE WITH MANUFACTURER SPECIFICATIONS AND INSTALLATION INSTRUCTIONS AND FRSA/TRI FLORIDA HIGH WIND TILE INSTALLATION MANUAL REVISED 5TH EDITION (FOR ASCE 7-10) OR 6TH EDITION (FOR ASCE 7-16). REFER TO PRODUCT APPROVAL TO VERIFY REQUIRED WIND PRESSURES ARE MET IF APPLICABLE.
5. ADEQUATE ATTIC VENTILATION IS REQUIRED. REFER TO UNDERLAYMENT AND PRIMARY ROOF SYSTEM MANUFACTURER'S INSTALLATION INSTRUCTIONS FOR VENTILATION LIMITATIONS. ALSO CHECK WITH LOCAL BUILDING CODES FOR RESTRICTIONS. NAILS USED TO ATTACH UNDERLAYMENT SHALL BE ANNUULAR RING OR DEFORMED SHANK ROOFING NAILS W/ 0.083" MINIMUM DIAMETER AND SUFFICIENT LENGTH TO PENETRATE THROUGH THE ROOF SHEATHING OR NOT LESS THAN 3/4" INTO THE ROOF SHEATHING W/ 1" DIAMETER BUTTON CAPS (METAL BUTTON CAPS ARE REQUIRED FOR ULTIMATE DESIGN WIND SPEED OF 160 MPH OR GREATER).
7. FORTIFIED HOME STANDARDS ARE TO BE APPLIED IN CONJUNCTION WITH FEDERAL, STATE, AND LOCAL CODES, ORDINANCES AND REGULATIONS IN ADDITION TO THE STRUCTURAL DESIGN WHICH IS BY OTHERS. IN CASE OF A CONFLICT BETWEEN PROVISIONS, USE WHICHEVER IS MORE STRINGENT.

FLASHING TAPE AT ALL PANEL SEAMS FULLY ADHERED W/ NO WRINKLES OR VOIDS USING ROLLER.

MATERIAL OPTION 1: 4" WIDE ASTM D1970 COMPLIANT SELF-ADHERING POLYMER - MODIFIED BITUMEN FLASHING TAPE MATERIAL OPTION 2: 3 - 3/4" WIDE AAMA 711-13 LEVEL 3 (FOR EXPOSURE UP TO 80°C/176°F) COMPLIANT SELF-ADHERING FLASHING TAPE.

ANCHOR SHEET COMPATIBLE WITH TILE ROOF ASSEMBLY: ASTM D226 TYPE II #30 UNDERLAYMENT INSTALLED AS SHOWN OR PER MANUFACTURER SPECIFICATIONS IF MORE STRINGENT.

HOLD BACK BUTTON CAPS AT EDGES TO AVOID INSTALLING DRIP EDGE OVER BUTTON CAPS. DRIP EDGE SHALL BE INSTALLED PER F-DE-1

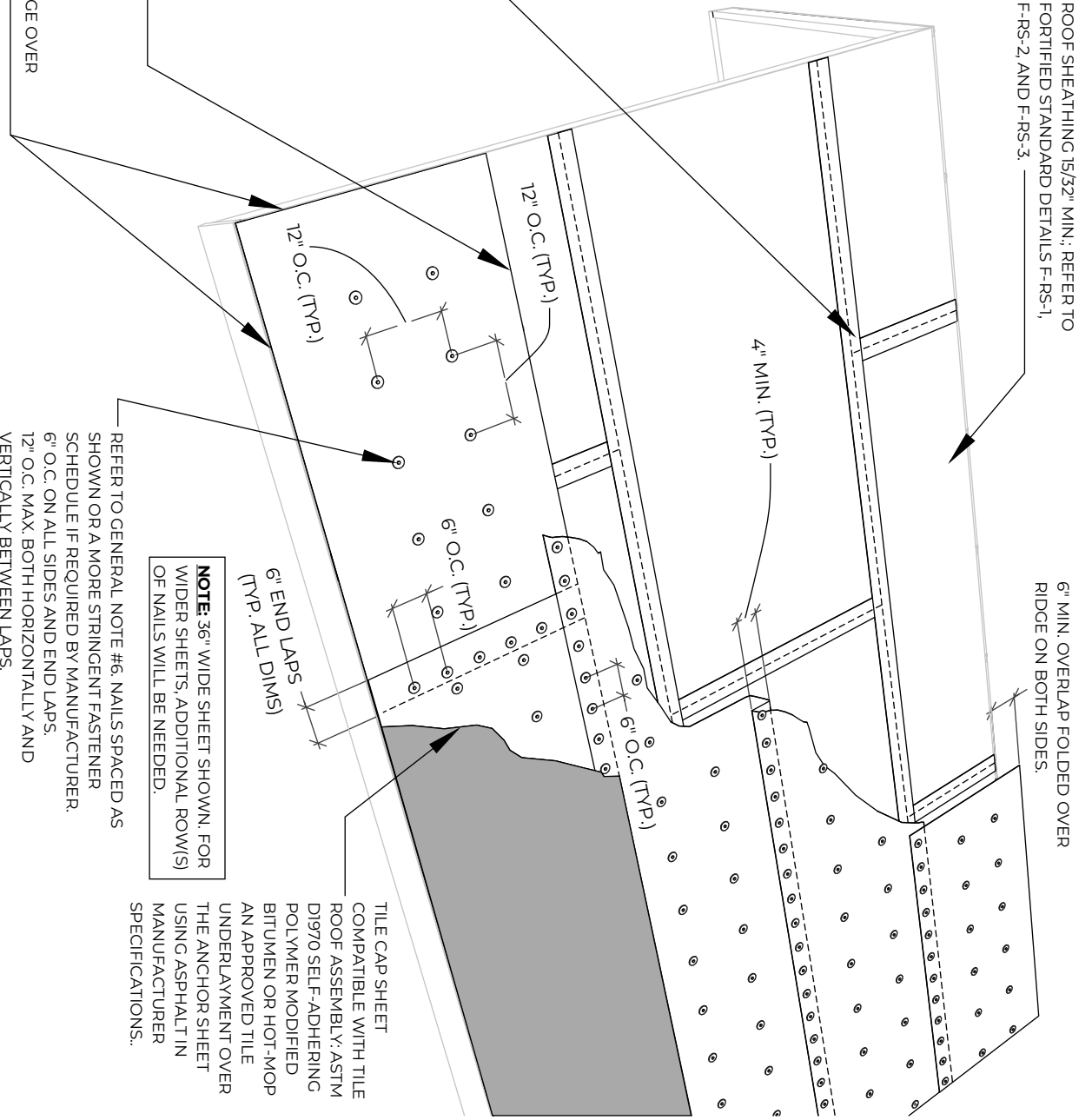

NOTE: 36" WIDE SHEET SHOWN, FOR WIDER SHEETS, ADDITIONAL ROW(S) OF NAILS WILL BE NEEDED.

REFER TO GENERAL NOTE #6. NAILS SPACED AS SHOWN OR A MORE STRINGENT FASTENER SCHEDULE IF REQUIRED BY MANUFACTURER.

6" O.C. ON ALL SIDES AND END LAPS.

12" O.C. MAX. BOTH HORIZONTALLY AND VERTICALLY BETWEEN LAPS.

TILE CAP SHEET COMPATIBLE WITH TILE ROOF ASSEMBLY: ASTM D1970 SELF-ADHERING POLYMER MODIFIED BITUMEN OR HOT-MOP AN APPROVED TILE UNDERLAYMENT OVER THE ANCHOR SHEET USING ASPHALT IN MANUFACTURER SPECIFICATIONS.

APPLICABLE STANDARDS:

FORTIFIED HOME™ - HURRICANE (2020)
 FORTIFIED HOME™ - HIGH WIND (2020)

DESCRIPTION:

STEEP SLOPE SEALED ROOF DECK - FLASHING TAPE, UNDERLAYMENT AND ROOF TILE CAP SHEET - CONCRETE AND CLAY TILE ROOF COVERS

DRAWING #:

F-SRD-5

DATE:

11/01/2020



1. **GENERAL NOTES:**
REFER TO APPLICABLE FORTIFIED HOME STANDARDS FOR ADDITIONAL INFORMATION.
2. APPLICABLE FOR ROOF PITCH 2:12 OR GREATER.
3. REFER TO AND INSTALL IN ACCORDANCE WITH MANUFACTURER SPECIFICATIONS AND INSTALLATION INSTRUCTIONS AND FRSA/TRI FLORIDA HIGH WIND TILE INSTALLATION MANUAL REVISED 5TH EDITION (FOR ASCE 7-10) OR 6TH EDITION (FOR ASCE 7-16). REFER TO PRODUCT APPROVAL TO VERIFY REQUIRED WIND PRESSURES ARE MET IF APPLICABLE.
4. ADEQUATE ATTIC VENTILATION IS REQUIRED. REFER TO UNDERLAYMENT AND PRIMARY ROOF SYSTEM MANUFACTURERS' INSTALLATION INSTRUCTIONS FOR VENTILATION LIMITATIONS. ALSO CHECK WITH LOCAL BUILDING CODES FOR RESTRICTIONS.
5. FORTIFIED HOME STANDARDS ARE TO BE APPLIED IN CONJUNCTION WITH FEDERAL, STATE, AND LOCAL CODES, ORDINANCES AND REGULATIONS IN ADDITION TO THE STRUCTURAL DESIGN WHICH IS BY OTHERS. IN CASE OF A CONFLICT BETWEEN PROVISIONS, USE WHICHEVER IS MORE STRINGENT.

ROOF SHEATHING 15/32" MIN ;
REFER TO FORTIFIED STANDARD
DETAILS F-RS-1, F-RS-2, AND F-RS-3.
APPLY MANUFACTURER-SPECIFIED
COMPATIBLE PRIMER TO ROOF
SHEATHING PER MANUFACTURER
INSTALLATION INSTRUCTIONS.

4" MIN. SIDELAPS OR GREATER IF
SPECIFIED BY MANUFACTURERS
SPECIFICATIONS AND INSTALLATION
INSTRUCTIONS AND FRSA/TRI MANUAL
(SEE GENERAL NOTE #3).

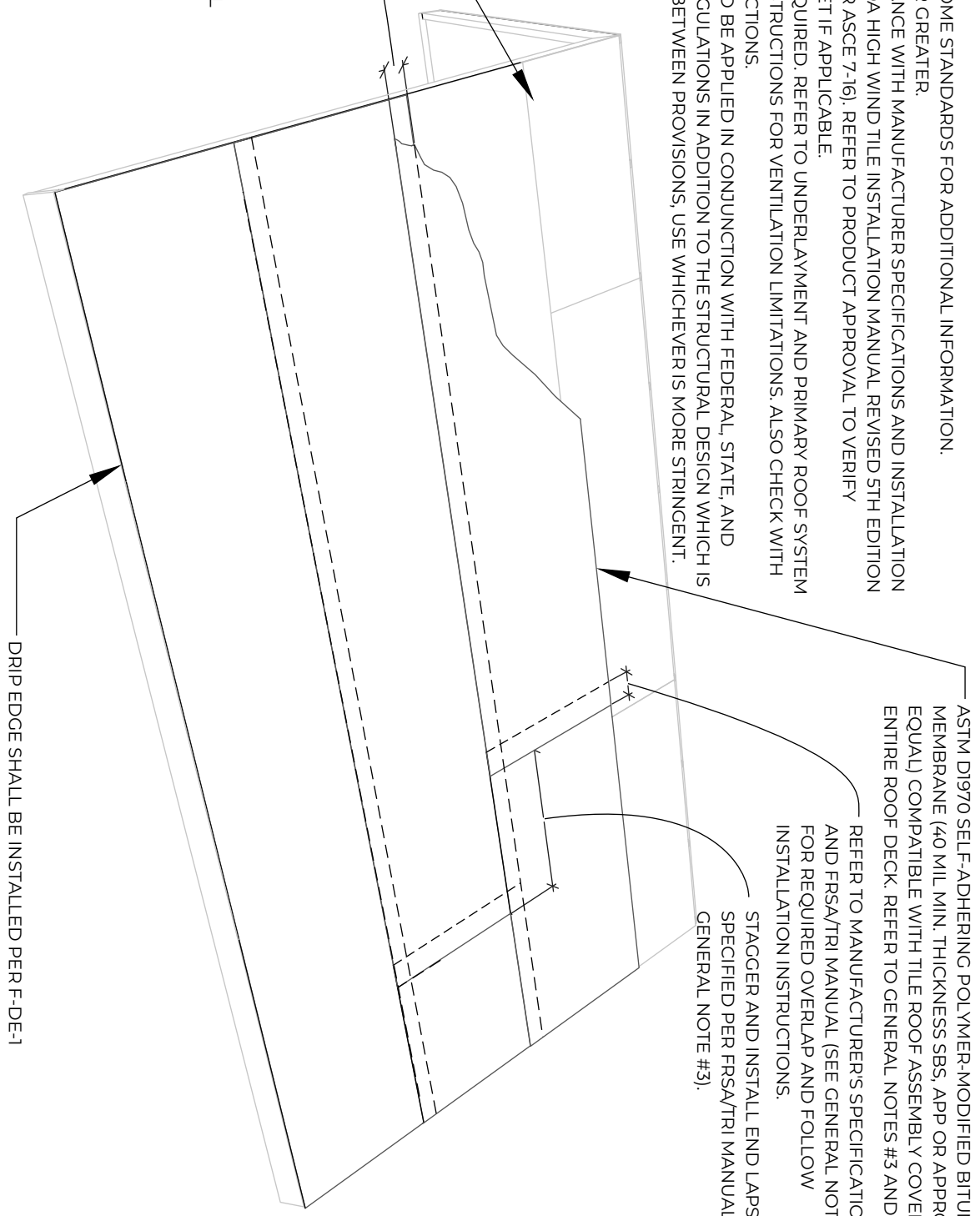

APPLICABLE STANDARDS:

FORTIFIED HOME™ - HURRICANE (2020)
FORTIFIED HOME™ - HIGH WIND (2020)

DESCRIPTION:

STEEP SLOPE SEALED ROOF DECK - SELF-
ADHERED MEMBRANE - CONCRETE AND CLAY
TILE ROOF COVERS

DRAWING #:

F-SRD-6

DATE:

11/01/2020



GENERAL NOTES:

1. REFER TO APPLICABLE FORTIFIED HOME STANDARDS FOR ADDITIONAL INFORMATION.
2. REFER TO FORTIFIED STANDARD DETAIL F-C-1 FOR CORROSION PROTECTION REQUIREMENTS.
3. WEAVE UNDERLAYMENT ACROSS VALLEYS.
4. DOUBLE LAP UNDERLAYMENT ACROSS RIDGES (UNLESS THERE IS A CONTINUOUS RIDGE VENT).
5. LAP UNDERLAYMENT WITH MINIMUM 6" LEG. *TURNED UP" AT WALL INTERSECTIONS; LAP WALL WEATHER BARRIER OVER TURNED-UP ROOF UNDERLAYMENT.
6. APPLICABLE FOR ROOF PITCH 2:12 OR GREATER.
7. NAILS USED TO ATTACH UNDERLAYMENT SHALL BE ANNULAR RING OR DEFORMED SHANK ROOFING NAILS W/ 0.083" MINIMUM DIAMETER AND SUFFICIENT LENGTH TO PENETRATE THROUGH THE ROOF SHEATHING OR NOT LESS THAN 3/4" INTO THE ROOF SHEATHING W/ 1" DIAMETER BUTTON CAPS (METAL BUTTON CAPS ARE REQUIRED FOR ULTIMATE DESIGN WIND SPEED OF 170 MPH OR GREATER).
8. FORTIFIED HOME STANDARDS ARE TO BE APPLIED IN CONJUNCTION WITH FEDERAL, STATE, AND LOCAL CODES, ORDINANCES AND REGULATIONS IN ADDITION TO THE STRUCTURAL DESIGN WHICH IS BY OTHERS, IN CASE OF A CONFLICT BETWEEN PROVISIONS, USE WHICHEVER IS MORE STRINGENT.

ROOF SHEATHING BY OTHERS; REFER TO FORTIFIED STANDARD DETAILS F-RS-1, F-RS-2, AND F-RS-3.

ASTM D8257 SYNTHETIC UNDERLAYMENT
 ALT: REINFORCED SYNTHETIC ROOF UNDERLAYMENT WITH ICC 188 APPROVAL AS ASTM D226 TYPE II; MINIMUM TEAR STRENGTH = 15 LBF PER ASTM D4533
 MINIMUM TENSILE STRENGTH = 20 PSF PER ASTM D5035
 PASS ASTM D4869 SHOWER TEST

6" MIN. OVERLAP FOLDED OVER RIDGE ON BOTH SIDES

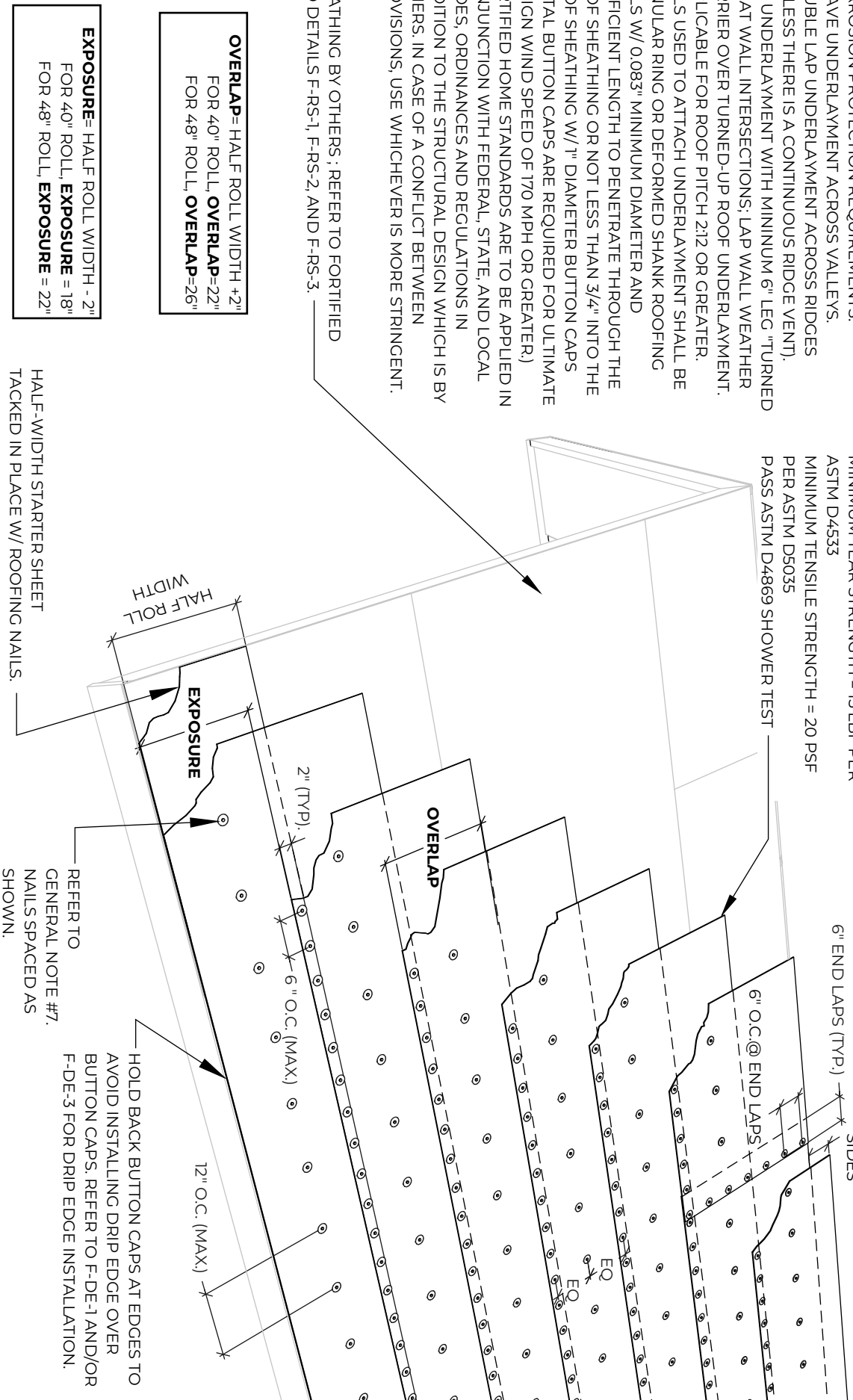

OVERLAP= HALF ROLL WIDTH +2"
 FOR 40" ROLL, **OVERLAP=22"**
 FOR 48" ROLL, **OVERLAP=26"**

EXPOSURE= HALF ROLL WIDTH - 2"
 FOR 40" ROLL, **EXPOSURE = 18"**
 FOR 48" ROLL, **EXPOSURE = 22"**

HALF-WIDTH STARTER SHEET
 TACKED IN PLACE W/ ROOFING NAILS.

APPLICABLE STANDARDS:

FORTIFIED HOME™ - HURRICANE (2020)
 FORTIFIED HOME™ - HIGH WIND (2020)

DESCRIPTION:

STEEP SLOPE SEALED ROOF DECK - TWO LAYERS SYNTHETIC UNDERLAYMENT (40" and 48" WIDE ROLLS)

DRAWING #:

F-SPD-7

DATE:

03/01/2023



1. GENERAL NOTES:
REFER TO APPLICABLE FORTIFIED HOME STANDARDS FOR ADDITIONAL INFORMATION.
2. REFER TO FORTIFIED STANDARD DETAIL F-G-1 FOR CORROSION PROTECTION REQUIREMENTS.
3. WEAVE UNDERLAYMENT ACROSS VALLEYS.
4. DOUBLE LAP UNDERLAYMENT ACROSS RIDGES (UNLESS THERE IS A CONTINUOUS RIDGE VENT).
5. LAP UNDERLAYMENT WITH MINIMUM 6" LEG. "TURNED UP" AT WALL INTERSECTIONS; LAP WALL WEATHER BARRIER OVER TURNED-UP ROOF UNDERLAYMENT.
6. APPLICABLE FOR ROOF PITCH 2:12 OR GREATER.
7. NAILS USED TO ATTACH UNDERLAYMENT SHALL BE ANNULAR RING OR DEFORMED SHANK ROOFING NAILS W/ 0.083" MINIMUM DIAMETER AND SUFFICIENT LENGTH TO PENETRATE THROUGH THE ROOF SHEATHING OR NOT LESS THAN 3/4" INTO THE ROOF SHEATHING W/ 1" DIAMETER BUTTON CAPS (METAL BUTTON CAPS ARE REQUIRED FOR ULTIMATE DESIGN WIND SPEED OF 170 MPH OR GREATER).
8. FORTIFIED HOME STANDARDS ARE TO BE APPLIED IN CONJUNCTION WITH FEDERAL, STATE, AND LOCAL CODES, ORDINANCES AND REGULATIONS IN ADDITION TO THE STRUCTURAL DESIGN WHICH IS BY OTHERS, IN CASE OF A CONFLICT BETWEEN PROVISIONS, USE WHICHEVER IS MORE STRINGENT.

ROOF SHEATHING BY OTHERS; REFER TO FORTIFIED STANDARD DETAILS F-RS-1, F-RS-2, AND F-RS-3.

ASTM D8257 SYNTHETIC UNDERLAYMENT
 ALT. REINFORCED SYNTHETIC ROOF UNDERLAYMENT WITH ICC 188
 APPROVAL AS ASTM D226 TYPE II;
 MINIMUM TEAR STRENGTH = 15 LBF PER ASTM D4533
 MINIMUM TENSILE STRENGTH = 20 PSF PER ASTM D5035
 PASS ASTM D4869 SHOWER TEST

30" STARTER SHEET
 TACKED IN PLACE W/ ROOFING NAILS.

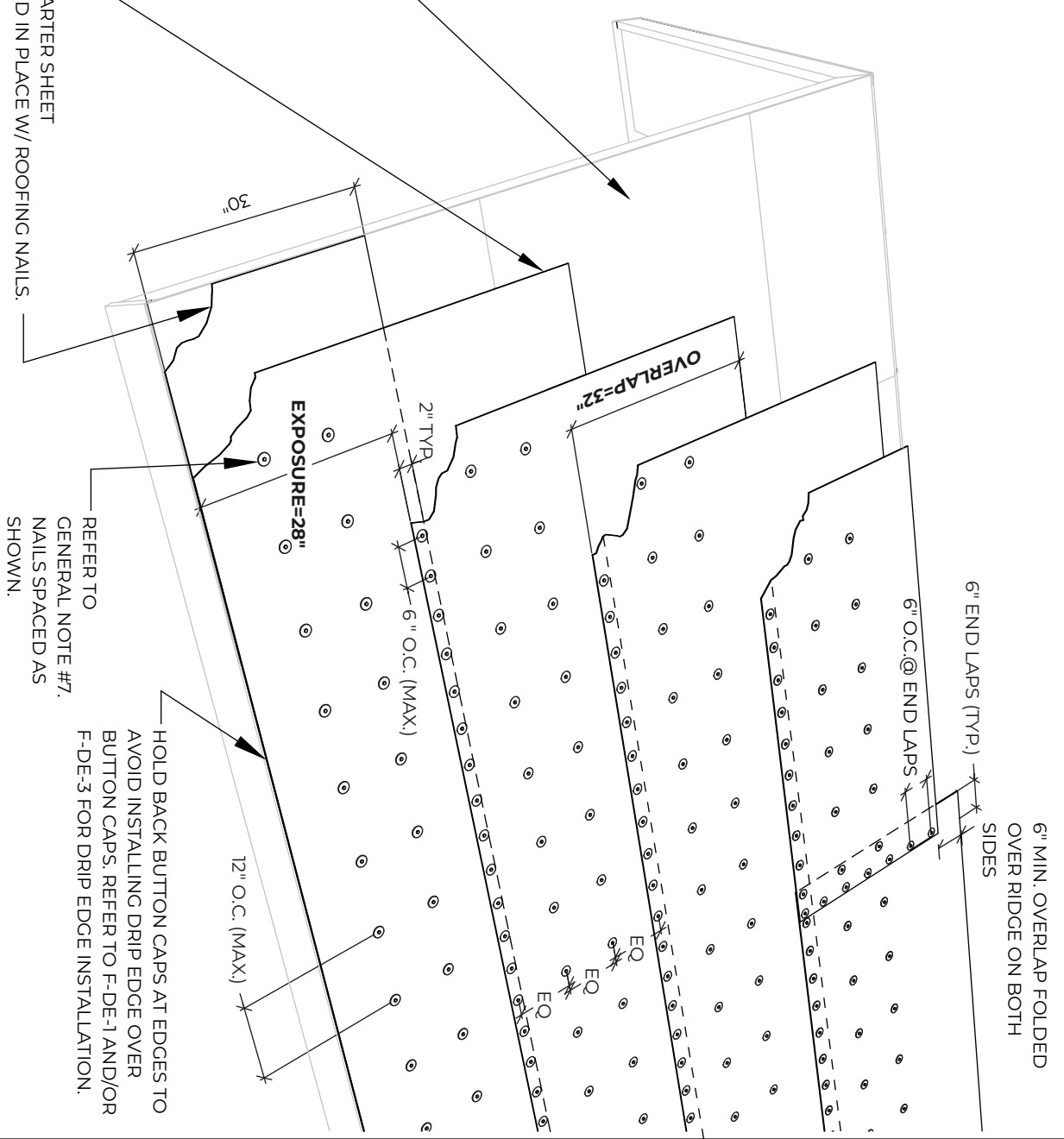

APPLICABLE STANDARDS:

FORTIFIED HOME™ - HURRICANE (2020)
 FORTIFIED HOME™ - HIGH WIND (2020)

DESCRIPTION:

STEEP SLOPE SEALED ROOF DECK -
 TWO LAYERS SYNTHETIC
 UNDERLAYMENT (60" WIDE ROLL)

DRAWING #:

F-SPD-8

DATE:

03/01/2023



GENERAL NOTES:

1. REFER TO APPLICABLE FORTIFIED HOME STANDARDS FOR ADDITIONAL INFORMATION. REFER TO FORTIFIED STANDARD DETAIL F-C-1 FOR CORROSION PROTECTION REQUIREMENTS.
2. BEST PRACTICES TO SEAL THE DRIP EDGE: SINGLE ROOF COVERS: SEAL THE DRIP EDGE, UNDERLAYMENT AND STARTER STRIP AT THE EAVE BY EITHER USING A SELF-ADHERING STARTER STRIP OR APPLYING AN 8" WIDE LAYER OF COMPATIBLE FLASHING CEMENT WITH 1/8" MAX. THICKNESS OVER THE DRIP EDGE AND UNDERLAYMENT.
3. FOR METAL ROOF COVERS: APPLY A COMPATIBLE MANUFACTURER-APPROVED SEALANT BETWEEN THE DRIP EDGE AND ADJACENT UNDERLAYMENT TO PREVENT WATER FROM ACCUMULATING UNDER THE DRIP EDGE OR USE A MANUFACTURER APPROVED 4" SELF-ADHERED SEAM TAPE.
4. APPLICABLE FOR ROOF PITCH 2:12 OR GREATER. FOR ROOF SLOPES LESS THAN 2:12, REFER TO MANUFACTURER'S DRIP EDGE INSTALLATION REQUIREMENTS.
5. FORTIFIED HOME STANDARDS ARE TO BE APPLIED IN CONJUNCTION WITH FEDERAL, STATE, AND LOCAL CODES, ORDINANCES AND REGULATIONS IN ADDITION TO THE STRUCTURAL DESIGN WHICH IS BY OTHERS. IN CASE OF A CONFLICT BETWEEN PROVISIONS, USE WHICHEVER IS MORE STRINGENT.

METAL DRIP EDGE (MINIMUM 26 GAUGE FOR STEEL) ALONG ALL EAVES AND GABLE RAKE EDGES INSTALLED OVER UNDERLAYMENT. MAKE SURE THE TOP SURFACE OF THE DRIP EDGE IS CLEAN, FREE OF OIL, AND IF REQUIRED BY THE STARTER STRIP MANUFACTURER, PRIMED WITH ASTM D41 PRIMER. FOR SEALING THE DRIP EDGE REFER TO GENERAL NOTE #3.

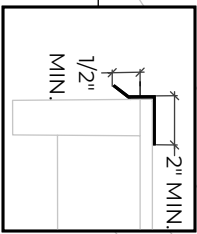
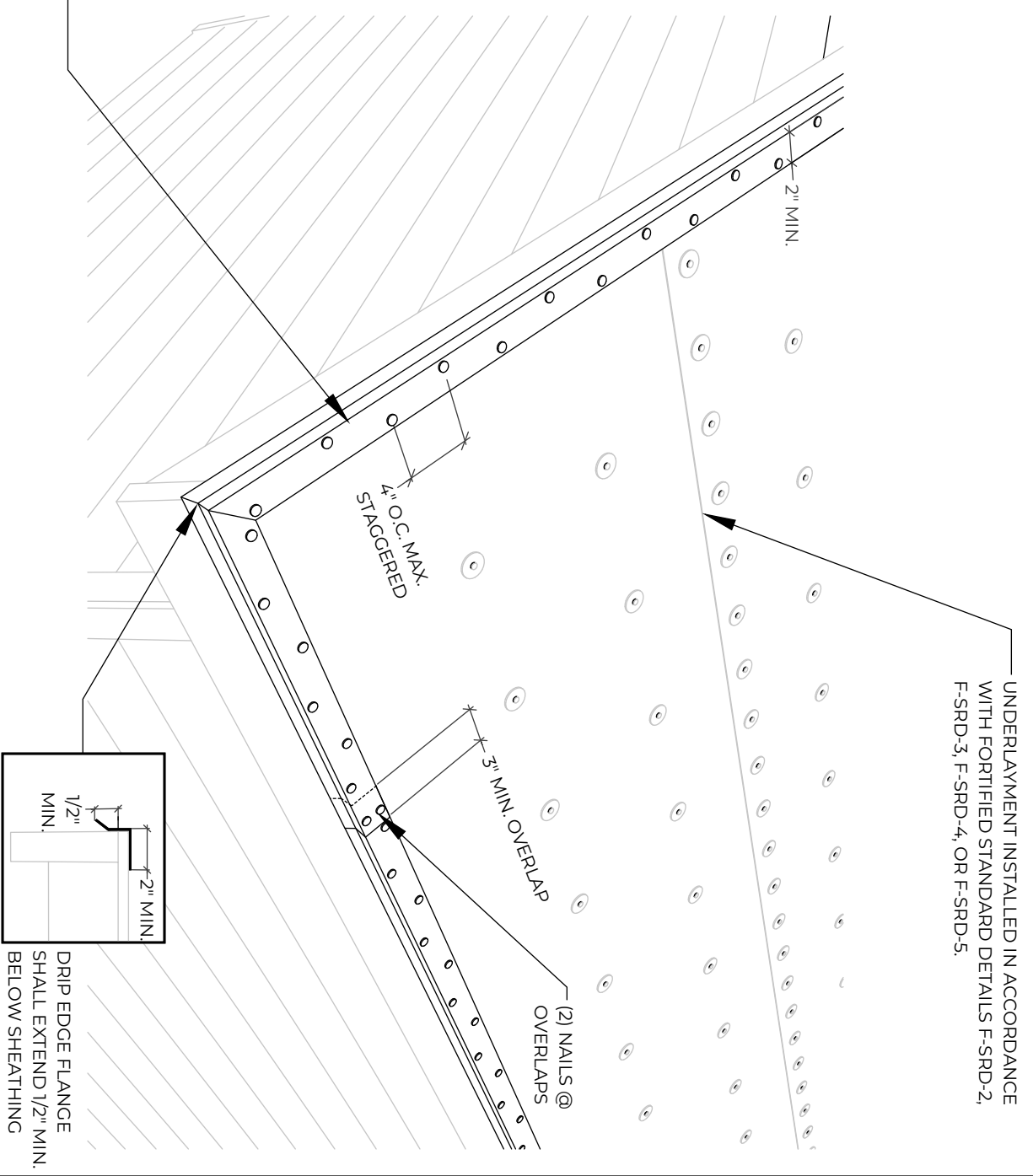

DRIP EDGE FLANGE SHALL EXTEND 1/2" MIN. BELOW SHEATHING

APPLICABLE STANDARDS:

FORTIFIED HOME™ - HURRICANE (2020)

DESCRIPTION:

HURRICANE - DRIP EDGE INSTALLATION OVER UNDERLAYMENT

DRAWING #:

F-DE-1

DATE:

11/01/2020



GENERAL NOTES:

1. REFER TO APPLICABLE FORTIFIED HOME STANDARDS FOR ADDITIONAL INFORMATION.
2. SHINGLES INSTALLED AT ALL INTERSECTIONS AND BOTH SIDES OF OPEN VALLEYS SHALL BE SET IN A MINIMUM 8 IN. WIDE STRIP OF FLASHING CEMENT (MAX. THICKNESS OF FLASHING CEMENT = 1/8"); CUT SIDE OF CLOSED VALLEYS SHALL BE SET IN A MINIMUM 2 IN. WIDE 1/8" THICK STRIP OF FLASHING CEMENT. WOVEN VALLEYS TO BE ACCORDING TO THE MANUFACTURER'S SPECIFICATIONS.
3. REFER TO FORTIFIED STANDARD DETAILS F-RC-2 AND F-RC-3 FOR ADDITIONAL ASPHALT SHINGLE INSTALLATION OPTIONS. FORTIFIED HOME STANDARDS ARE TO BE APPLIED IN CONJUNCTION WITH FEDERAL, STATE, AND LOCAL CODES, ORDINANCES AND REGULATIONS. IN ADDITION TO THE STRUCTURAL DESIGN WHICH IS BY OTHERS. IN CASE OF A CONFLICT BETWEEN PROVISIONS, USE WHICHEVER IS MORE STRINGENT.
- 4.

UNDERLAYMENT INSTALLED PER FORTIFIED STANDARD DETAILS F-SRD-2, F-SRD-3, OR F-SRD-4.

SHINGLE MANUFACTURER APPROVED ASTM D1970 FULLY ADHERED STARTER STRIP WITH ASPHALTIC ADHESIVE STRIP AT EAVE.

DRIP EDGE AND ASTM D41 ASPHALT PRIMER INSTALLED PER FORTIFIED STANDARD DETAIL F-DE-1 AND/OR F-DE-3.

STARTER STRIP AND SHINGLES SHALL NOT EXTEND MORE THAN 1/4" BEYOND DRIP EDGE.

ASTM D3161 (CLASS F) OR ASTM D7158 (CLASS H) ASPHALT SHINGLES INSTALLED PER MANUFACTURER RECOMMENDATIONS FOR HIGH WIND REGIONS.

TO MEET 2020 HAIL SUPPLEMENT REQUIREMENTS, ASPHALT SHINGLES MUST HAVE AN OVERALL IBHS ROOF SHINGLE HAIL IMPACT RATING OF "GOOD" OR "EXCELLENT" OR BE POLYMER-MODIFIED WITH EITHER A UL 2218 CLASS 4 OR FM 4473 CLASS 4 RATING.

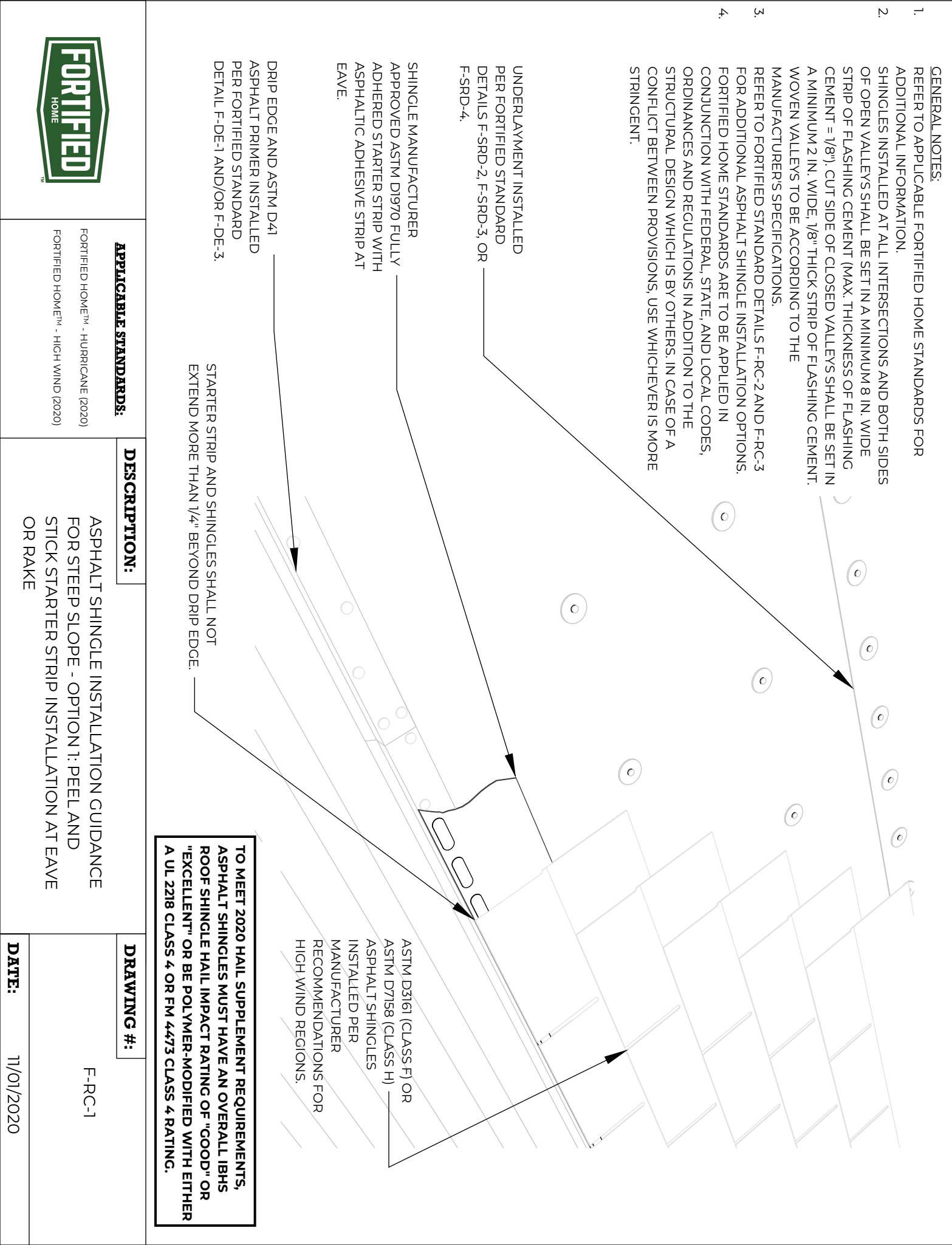

APPLICABLE STANDARDS:

FORTIFIED HOME™ - HURRICANE (2020)
FORTIFIED HOME™ - HIGH WIND (2020)

DESCRIPTION:

ASPHALT SHINGLE INSTALLATION GUIDANCE FOR STEEP SLOPE - OPTION 1: PEEL AND STICK STARTER STRIP INSTALLATION AT EAVE OR RAKE

DRAWING #:

F-RC-1

DATE:

11/01/2020



GENERAL NOTES:

1. REFER TO APPLICABLE FORTIFIED HOME STANDARDS FOR ADDITIONAL INFORMATION.
2. SHINGLES INSTALLED AT ALL INTERSECTIONS AND BOTH SIDES OF OPEN VALLEYS SHALL BE SET IN A MINIMUM 8 IN. WIDE STRIP OF FLASHING CEMENT (MAX. THICKNESS OF FLASHING CEMENT = 1/8"). CUT SIDE OF CLOSED VALLEYS SHALL BE SET IN A MINIMUM 2 IN. WIDE, 1/8" THICK STRIP OF FLASHING CEMENT. WOVEN VALLEYS TO BE ACCORDING TO THE MANUFACTURERS SPECIFICATIONS.
3. REFER TO FORTIFIED STANDARD DETAILS F-RC-1 AND F-RC-3 FOR ADDITIONAL ASPHALT SHINGLE INSTALLATION OPTIONS. FORTIFIED HOME STANDARDS ARE TO BE APPLIED IN CONJUNCTION WITH FEDERAL, STATE, AND LOCAL CODES, ORDINANCES AND REGULATIONS IN ADDITION TO THE STRUCTURAL DESIGN WHICH IS BY OTHERS. IN CASE OF A CONFLICT BETWEEN PROVISIONS, USE WHICHEVER IS MORE STRINGENT.
4. UNDERLAYMENT INSTALLED PER FORTIFIED STANDARD DETAILS F-SRD-2, F-SRD-3, OR F-SRD-4.

SHINGLE MANUFACTURER APPROVED STARTER STRIP SET IN A MINIMUM 8 IN. WIDE STRIP OF COMPATIBLE FLASHING CEMENT (MAX. THICKNESS OF FLASHING CEMENT = 1/8").

VERIFY WITH MANUFACTURER THAT FLASHING CEMENT/ROOF MASTIC IS COMPATIBLE WITH UNDERLAYMENT.

DRIP EDGE AND ASTM D41 ASPHALT PRIMER INSTALLED PER FORTIFIED STANDARD DETAIL F-DE-1 AND/OR F-DE-3.

STARTER STRIP AND SHINGLES SHALL NOT EXTEND MORE THAN 1/4 IN. BEYOND DRIP EDGE.

ASTM D3161 (CLASS F) OR ASTM D7158 (CLASS H) ASPHALT SHINGLES INSTALLED PER MANUFACTURER RECOMMENDATIONS FOR HIGH WIND REGIONS.

TO MEET 2020 HAIL SUPPLEMENT REQUIREMENTS, ASPHALT SHINGLES MUST HAVE AN OVERALL IBHS ROOF SHINGLE HAIL IMPACT RATING OF "GOOD" OR "EXCELLENT" OR BE POLYMER-MODIFIED WITH EITHER A UL 2218 CLASS 4 OR FM 4473 CLASS 4 RATING.

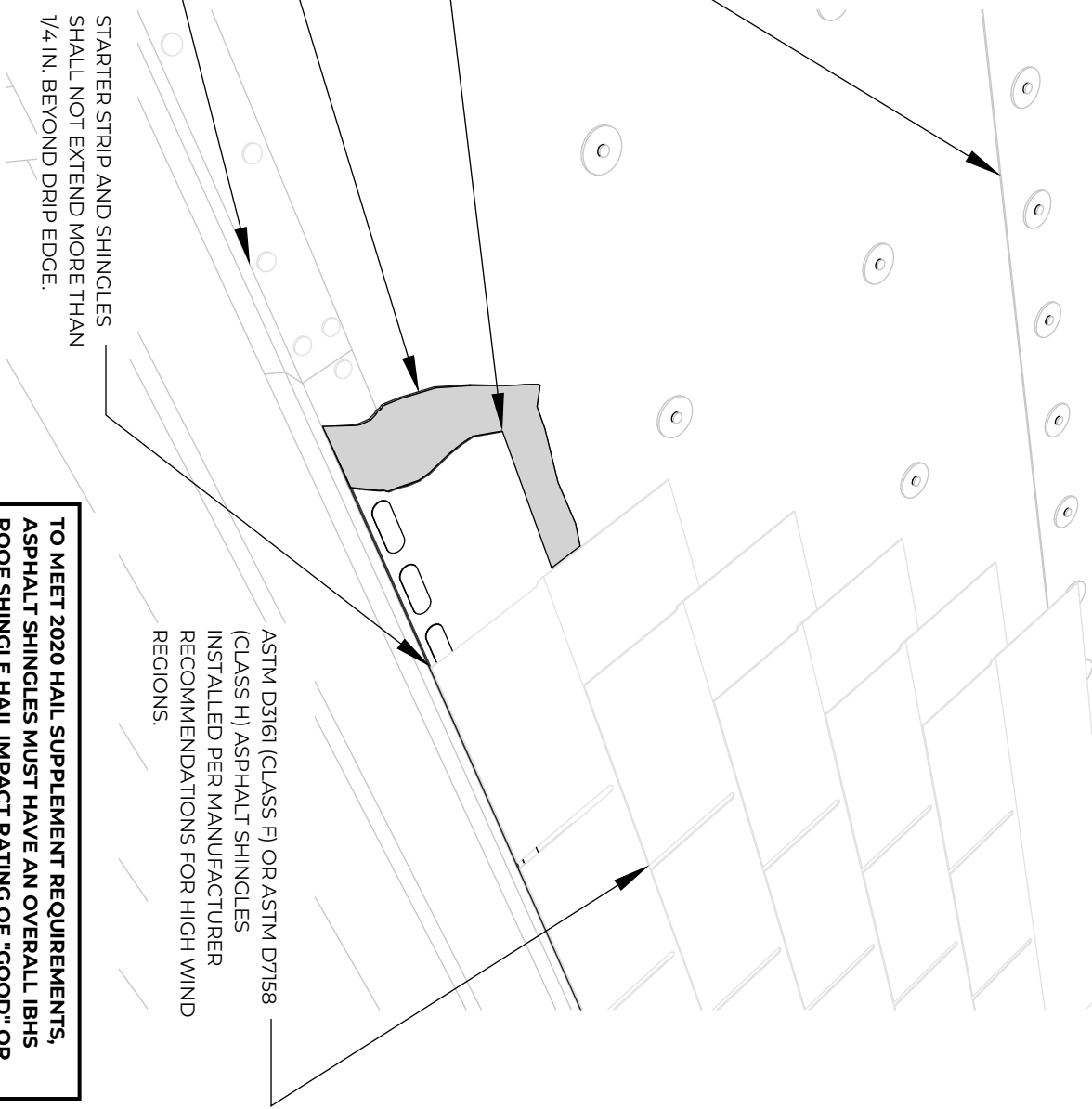

APPLICABLE STANDARDS:

FORTIFIED HOME™ - HURRICANE (2020)
FORTIFIED HOME™ - HIGH WIND (2020)

DESCRIPTION:

ASPHALT SHINGLE INSTALLATION GUIDANCE FOR STEEP SLOPE - OPTION 2: SHINGLE STRIP STARTER INSTALLATION AT EAVE OR RAKE

DRAWING #:

F-RC-2

DATE:

11/01/2020



GENERAL NOTES:

1. REFER TO APPLICABLE FORTIFIED HOME STANDARDS FOR ADDITIONAL INFORMATION.
2. SHINGLES INSTALLED AT ALL INTERSECTIONS AND BOTH SIDES OF OPEN VALLEYS SHALL BE SET IN A MINIMUM 8 IN. WIDE STRIP OF FLASHING CEMENT (MAX. THICKNESS OF FLASHING CEMENT = 1/8"). CUT SIDE OF CLOSED VALLEYS SHALL BE SET IN A MINIMUM 2 IN. WIDE, 1/8" THICK STRIP OF FLASHING CEMENT. WOVEN VALLEYS TO BE ACCORDING TO THE MANUFACTURER'S SPECIFICATIONS.
3. REFER TO FORTIFIED STANDARD DETAILS F-RC-1 AND F-RC-2 FOR ADDITIONAL ASPHALT SHINGLE INSTALLATION OPTIONS. FORTIFIED HOME STANDARDS ARE TO BE APPLIED IN CONJUNCTION WITH FEDERAL, STATE, AND LOCAL CODES, ORDINANCES AND REGULATIONS. IN ADDITION TO THE STRUCTURAL DESIGN WHICH IS BY OTHERS. IN CASE OF A CONFLICT BETWEEN PROVISIONS, USE WHICHEVER IS MORE STRINGENT.
- 4.

UNDERLAYMENT INSTALLED PER FORTIFIED STANDARD DETAILS F-SRD-2, F-SRD-3, OR F-SRD-4.

DRIP EDGE AND ASTM D41 ASPHALT PRIMER INSTALLED PER FORTIFIED STANDARD DETAIL F-DE-1 AND/OR F-DE-3.

SHINGLES SET DIRECTLY IN A MINIMUM 8 IN. WIDE STRIP OF COMPATIBLE FLASHING CEMENT (MAX. THICKNESS OF FLASHING CEMENT = 1/8"). VERIFY WITH MANUFACTURER THAT FLASHING CEMENT/ROOF MASTIC IS COMPATIBLE WITH UNDERLAYMENT.

TO MEET 2020 HAIL SUPPLEMENT REQUIREMENTS, ASPHALT SHINGLES MUST HAVE AN OVERALL IBHS ROOF SHINGLE HAIL IMPACT RATING OF "GOOD" OR "EXCELLENT" OR BE POLYMER-MODIFIED WITH EITHER A UL 2218 CLASS 4 OR FM 4473 CLASS 4 RATING.

ASTM D3161 (CLASS F) OR ASTM D7158 (CLASS H) ASPHALT SHINGLES INSTALLED PER MANUFACTURER RECOMMENDATIONS FOR HIGH WIND REGIONS. SHINGLES SHALL NOT EXTEND MORE THAN 1/4" BEYOND DRIP EDGE.



APPLICABLE STANDARDS:

FORTIFIED HOME™ - HURRICANE (2020)
FORTIFIED HOME™ - HIGH WIND (2020)

DESCRIPTION:

ASPHALT SHINGLE INSTALLATION
GUIDANCE FOR STEEP SLOPE - OPTION 3:
SHINGLES SET DIRECTLY IN FLASHING
CEMENT AT RAKE ONLY

DRAWING #:

F-RC-3

DATE:

11/01/2020



1. GENERAL NOTES:
REFER TO APPLICABLE FORTIFIED HOME STANDARDS FOR ADDITIONAL INFORMATION. WHEN REPLACING AN ENTIRE DAMAGED SHEET WITH A DIMENSION OF LESS THAN 24" IN ANY DIRECTION, PROVIDE 2X4 BLOCKING ALONG ALL UNSUPPORTED EDGES, AND FASTEN SHEATHING IN ACCORDANCE WITH F-RR-3 AND F-RR-4.
2. FORTIFIED HOME STANDARDS ARE TO BE APPLIED IN CONJUNCTION WITH FEDERAL, STATE, AND LOCAL CODES, ORDINANCES AND REGULATIONS IN ADDITION TO THE STRUCTURAL DESIGN WHICH IS BY OTHERS. IN CASE OF A CONFLICT BETWEEN PROVISIONS, USE WHICHEVER IS MORE STRINGENT.
3. AT PANEL ENDS, PROVIDE 2 X 4 SCAB FASTENED TO EXISTING MEMBER W/ 16D NAILS @ 4" O.C. STAGGERED, TYP. OF (2).

EXISTING ROOF SHEATHING BY OTHERS W/ 7/16" MIN. THICKNESS AND NO DAMAGE OR DETERIORATION. REFER TO FORTIFIED STANDARD DETAILS F-RR-3 AND F-RR-4 FOR RE-NAILING SCHEDULE.

REFER TO FORTIFIED STANDARD DETAILS F-RR-3 AND F-RR-4 FOR REQUIRED NAILING. ATTACH NEW ROOF DECK TO SCAB (NOT EXISTING ROOF MEMBER), TYP.

PREVIOUSLY DAMAGED ROOF DECK AREA. INSPECT ROOF SUPPORT MEMBERS BELOW FOR DETERIORATION OR DAMAGE AND REPLACE ENTIRE SHEET.

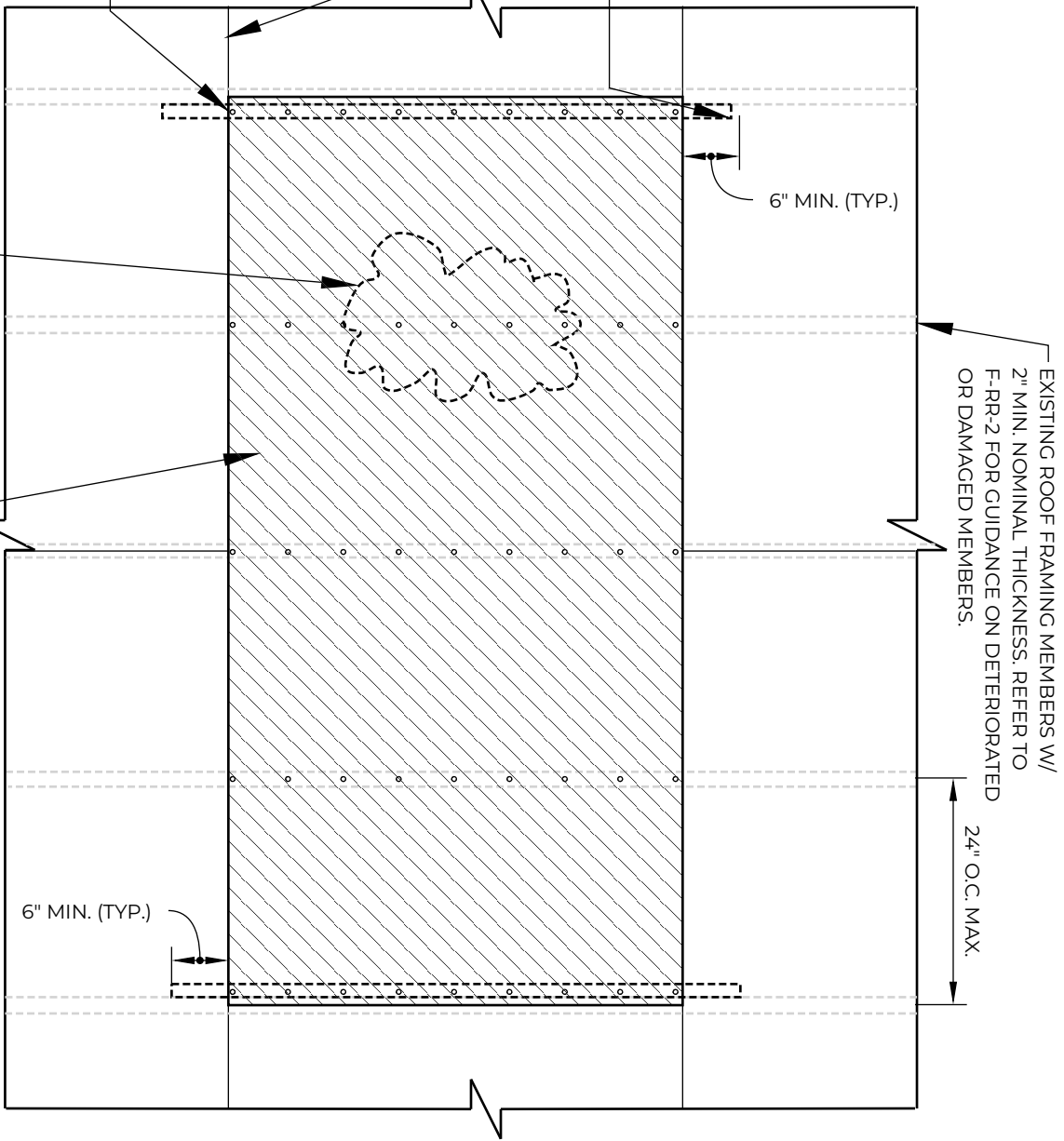

NEW ROOF DECK REPLACEMENT FASTENED TO SCAB, BLOCKINGS (IF APPLICABLE) AND EXISTING FRAMING IN ACCORDANCE WITH FORTIFIED STANDARD DETAILS F-RR-3 AND F-RR-4.

APPLICABLE STANDARDS:

FORTIFIED HOME™ - HURRICANE (2020)
FORTIFIED HOME™ - HIGH WIND (2020)

DESCRIPTION:

RE-ROOFING DECK REPLACEMENT
FASTENING DETAIL

DRAWING #:

F-RR-1

DATE:

11/01/2020



- GENERAL NOTES:
1. REFER TO APPLICABLE FORTIFIED HOME STANDARDS FOR ADDITIONAL INFORMATION. SCAB WOOD MEMBERS MAY BE TRIMMED UP TO A MAXIMUM OF 1/2" AT THE BOTTOM TO FACILITATE INSTALLATION.
 2. IF DAMAGE IS GREATER THAN THE CONDITIONS SHOWN, CONSULT A LICENSED PROFESSIONAL ENGINEER TO PROVIDE ENGINEERING DETAILS TO REPAIR THE DAMAGE. DAMAGED/DETERIORATED AREA MUST BE A MINIMUM OF 6 IN. AWAY FROM ANY MECHANICAL CONNECTIONS (I.E. TRUSS/RAFTER HANGERS, TRUSS CONNECTOR PLATES, ETC.)
 3. WHEN THE FASCIA OR SUB-FASCIA IS THE ROOF FRAMING MEMBER THAT IS DAMAGED OR DETERIORATED, REMOVE AND REPLACE THE DAMAGED/DETERIORATED SECTION PLUS AT LEAST 2 FT. BEYOND THAT SECTION ON EACH SIDE.
 4. FORTIFIED HOME STANDARDS ARE TO BE APPLIED IN CONJUNCTION WITH FEDERAL, STATE, AND LOCAL CODES, ORDINANCES AND REGULATIONS IN ADDITION TO THE STRUCTURAL DESIGN WHICH IS BY OTHERS. IN CASE OF A CONFLICT BETWEEN PROVISIONS, USE WHICHEVER IS MORE STRINGENT.

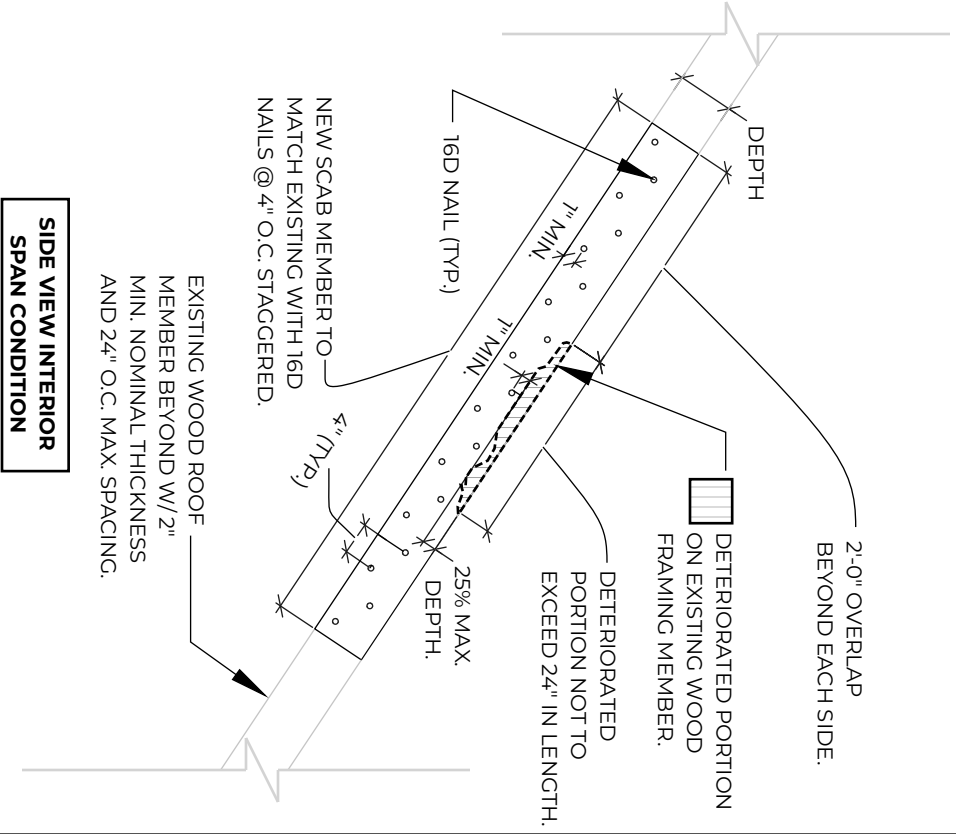
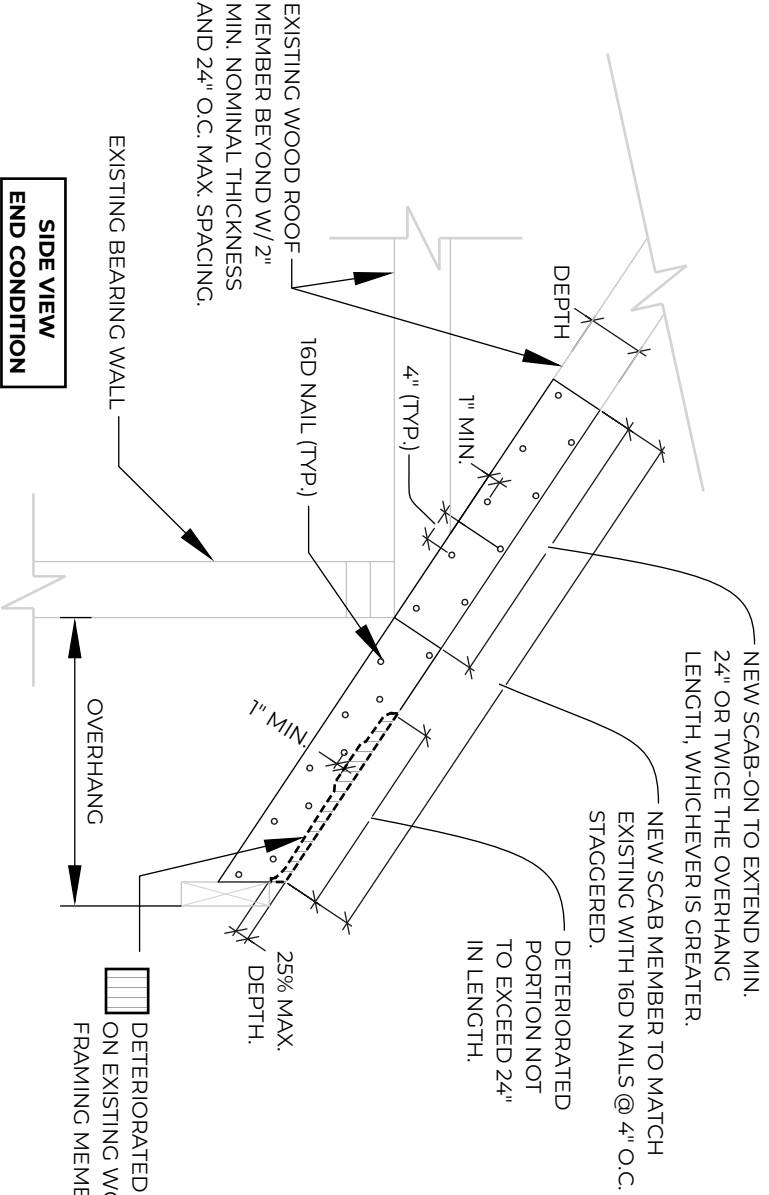

APPLICABLE STANDARDS:

FORTIFIED HOME™ - HURRICANE (2020)
 FORTIFIED HOME™ - HIGH WIND (2020)

DESCRIPTION:

RE-ROOFING NEW SCAB MEMBER DETAIL
 FOR DAMAGED OR DETERIORATED
 WOOD FRAMING MEMBER

DRAWING #:

F-RR-2

DATE:

11/01/2020



- GENERAL NOTES:**
REFER TO APPLICABLE FORTIFIED HOME STANDARDS FOR ADDITIONAL INFORMATION.
- FORTIFIED HOME STANDARDS ARE TO BE APPLIED IN CONJUNCTION WITH FEDERAL, STATE, AND LOCAL CODES, ORDINANCES AND REGULATIONS IN ADDITION TO THE STRUCTURAL DESIGN WHICH IS BY OTHERS. IN CASE OF A CONFLICT BETWEEN PROVISIONS, USE WHICHEVER IS MORE STRINGENT.

○ EXISTING FASTENERS, IF IT CAN BE DOCUMENTED THAT EXISTING NAILING MEETS THE REQUIREMENTS OF F-RR-2, THEN SUPPLEMENTAL FASTENING (+) IS NOT REQUIRED.

+ ADDITIONAL 0.173" X 2-3/8" 8D RING SHANK NAILS @ = 4" O.C.

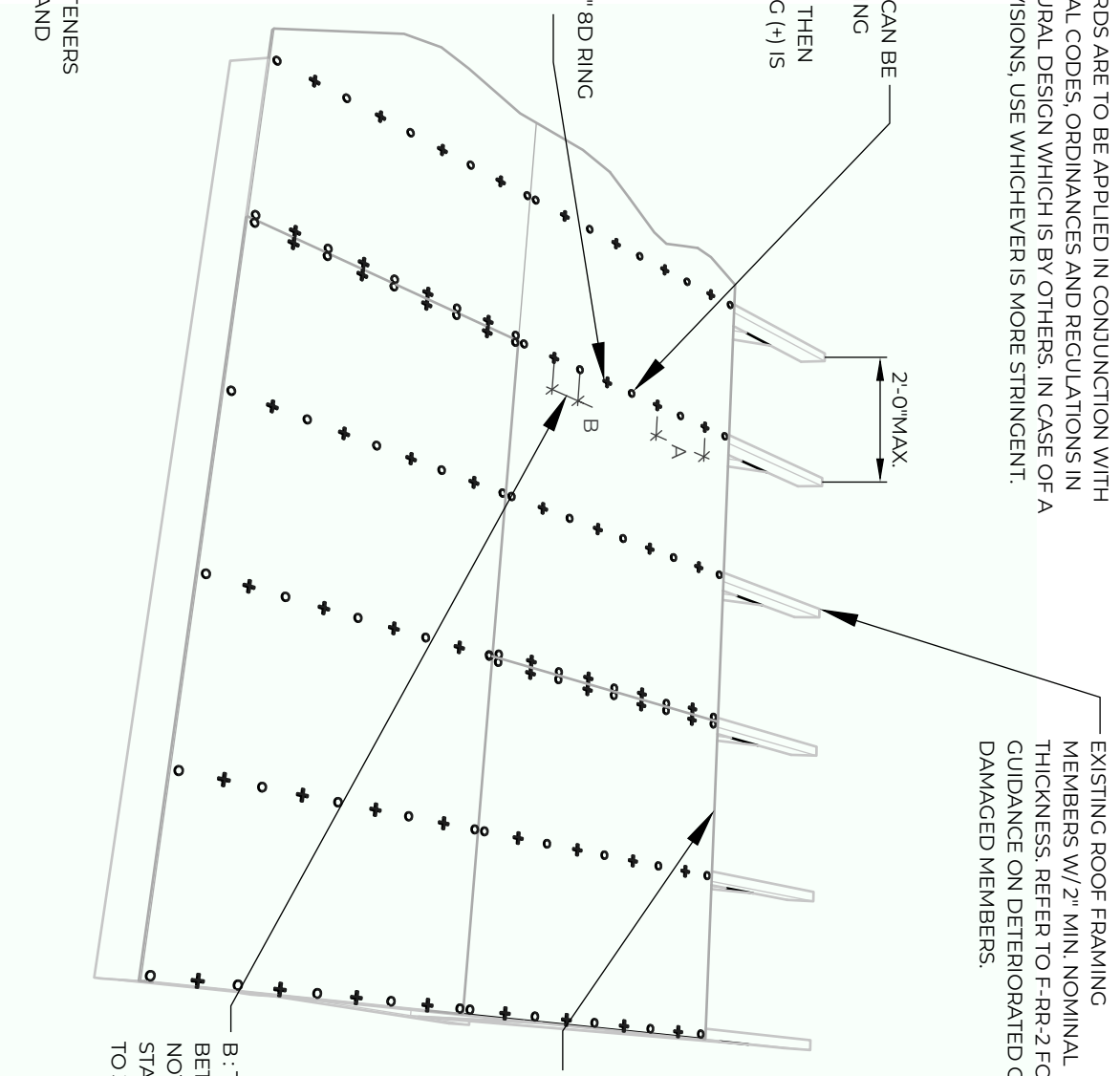

EXISTING ROOF FRAMING MEMBERS W/ 2" MIN. NOMINAL THICKNESS. REFER TO F-RR-2 FOR GUIDANCE ON DETERIORATED OR DAMAGED MEMBERS.

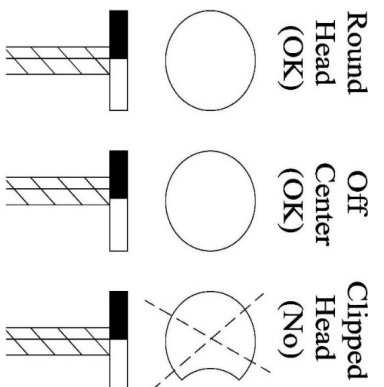

FIGURE 1.

EXISTING STRUCTURAL WOOD PANEL ROOF SHEATHING (PLYWOOD OR OSB) W/ NO DAMAGE OR DETERIORATION. REFER TO F-RR-1 FOR DAMAGED OR DETERIORATED SHEATHING. REFER TO F-RS-2 FOR SHEATHING THICKNESS REQUIREMENTS.

B : TO AVOID WOOD SPLITTING, SPACING BETWEEN NEW AND EXISTING NAILS "B" SHALL NOT BE LESS THAN 2 IN. NAILS SHALL BE STAGGERED WHEN "B" IS LESS THAN OR EQUAL TO 3 IN.

KEY:
○ = EXISTING FASTENERS
+ = ADDITIONAL FASTENERS
A = SPACING OF ADDITIONAL FASTENERS
B = SPACING BETWEEN EXISTING AND ADDITIONAL FASTENER

APPLICABLE STANDARDS:

FORTIFIED HOME™ - HURRICANE (2020)

DESCRIPTION:

HURRICANE - RE-NAILING THE ROOF DECK (WOOD STRUCTURAL PANELS)

DRAWING #:

F-RR-3

DATE:

11/01/2020



- GENERAL NOTES:**
- REFER TO APPLICABLE FORTIFIED HOME STANDARDS FOR ADDITIONAL INFORMATION.
 - APPLICABLE FOR ROOF PITCH 2:12 OR GREATER.
 - LOCAL BUILDING CODE REQUIREMENTS FOR ROOF SHEATHING THICKNESS AND/OR NAIL SIZE/ATTACHMENT SPACING MAY BE MORE STRINGENT BASED ON SITE CONDITIONS.
 - FOR CONCRETE AND CLAY TILE ROOF COVERS, MINIMUM REQUIRED SHEATHING THICKNESS IS 15/32".
 - FULL ROUND HEAD DIAMETER; NO CLIPPED-HEAD NAILS, COMMON NAILS OR STAPLES SHALL BE ALLOWED. REFER TO FIGURE 1.
 - FORTIFIED HOME STANDARDS ARE TO BE APPLIED IN CONJUNCTION WITH FEDERAL, STATE, AND LOCAL CODES, ORDINANCES AND REGULATIONS IN ADDITION TO THE STRUCTURAL DESIGN WHICH IS BY OTHERS. IN CASE OF A CONFLICT BETWEEN PROVISIONS, USE WHICHEVER IS MORE STRINGENT.

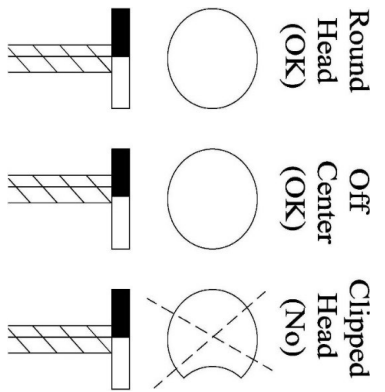
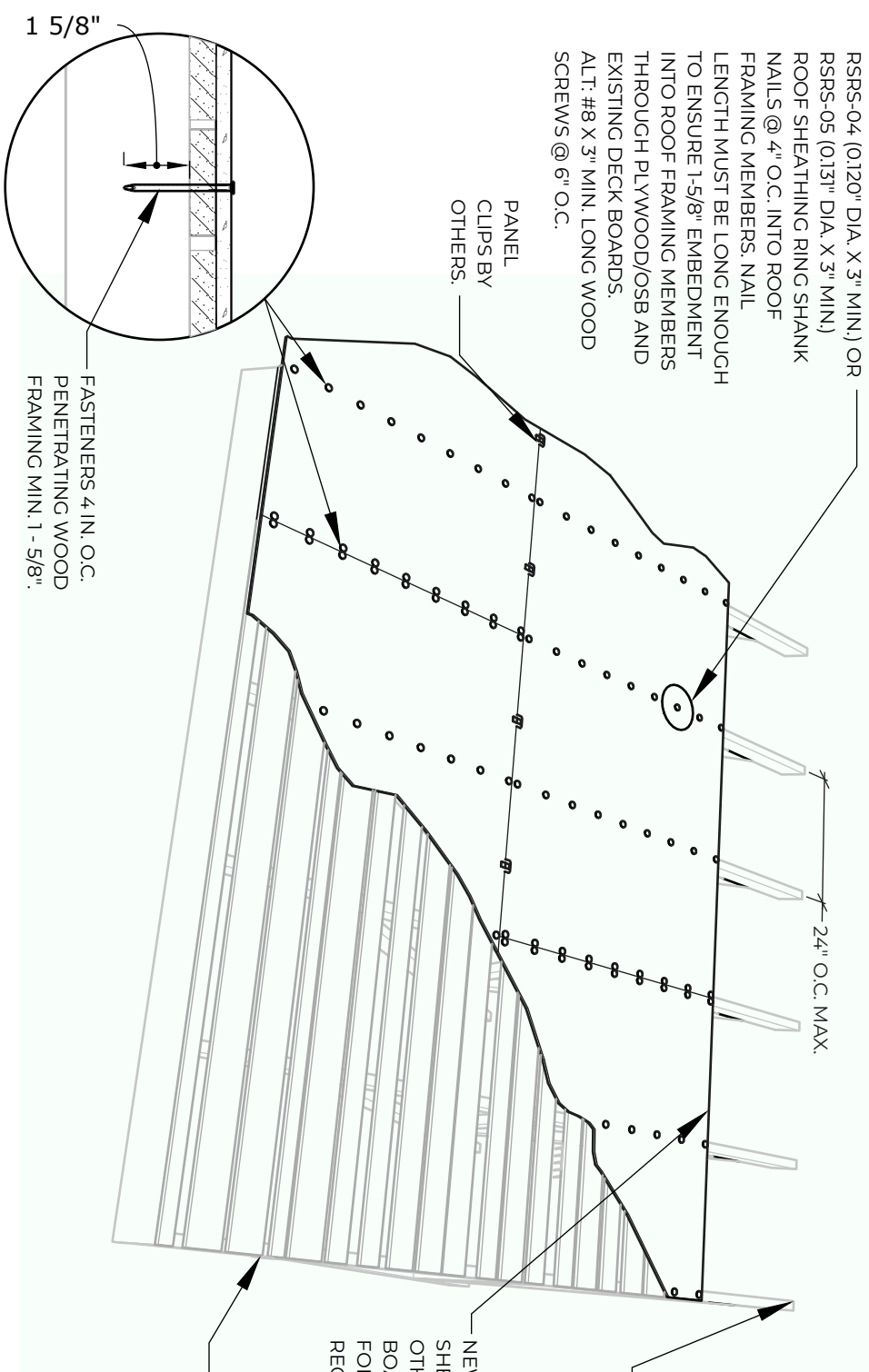

FIGURE 1.

RSRS-04 (0.120" DIA. X 3" MIN.) OR
RSRS-05 (0.131" DIA. X 3" MIN.)
ROOF SHEATHING RING SHANK
NAILS @ 4" O.C. INTO ROOF
FRAMING MEMBERS. NAIL
LENGTH MUST BE LONG ENOUGH
TO ENSURE 1-5/8" EMBEDMENT
INTO ROOF FRAMING MEMBERS
THROUGH PLYWOOD/OSB AND
EXISTING DECK BOARDS.
ALT: #8 X 3" MIN. LONG WOOD
SCREWS @ 6" O.C.



FASTENERS 4 IN. O.C.
PENETRATING WOOD
FRAMING MIN. 1 - 5/8"

APPLICABLE STANDARDS:

FORTIFIED HOME™ - HURRICANE (2020)
FORTIFIED HOME™ - HIGH WIND (2020)

DESCRIPTION:

FASTENING WOOD STRUCTURAL
PANEL ROOF SHEATHING OVER
EXISTING 1X ROOF DECK BOARDS
WITH GAPS

DRAWING #:

F-RR-5

DATE:

11/01/2020



- GENERAL NOTES:
- REFER TO APPLICABLE FORTIFIED HOME STANDARDS FOR ADDITIONAL INFORMATION.
 - REFER TO FORTIFIED STANDARD DETAIL F-G-1 FOR CORROSION PROTECTION REQUIREMENTS.
 - TO MAINTAIN PROPER ATTIC VENTILATION, VENT SHUTTERING MAY BE PERFORMED ON A TEMPORARY BASIS ONLY AND SHUTTERS ARE TO BE REMOVED AFTER A STORM THREAT IS OVER. ADEQUATE ATTIC VENTILATION MUST BE MAINTAINED ON A REGULAR BASIS.**
 - FORTIFIED HOME STANDARDS ARE TO BE APPLIED IN CONJUNCTION WITH FEDERAL, STATE, AND LOCAL CODES, ORDINANCES AND REGULATIONS IN ADDITION TO THE STRUCTURAL DESIGN WHICH IS BY OTHERS. IN CASE OF A CONFLICT BETWEEN PROVISIONS, USE WHICHEVER IS MORE STRINGENT.

WOOD STRUCTURAL PANEL OR OTHER NONPOROUS FLAT SHUTTER CUT TO FIT W/ 7/16" MIN. THICKNESS. PRE-DRILL HOLES AT FASTENER LOCATIONS. SHAPE MAY VARY, BUT NOT TO EXCEED MAX. DIMENSIONS AND FASTENER SPACING SHOWN.

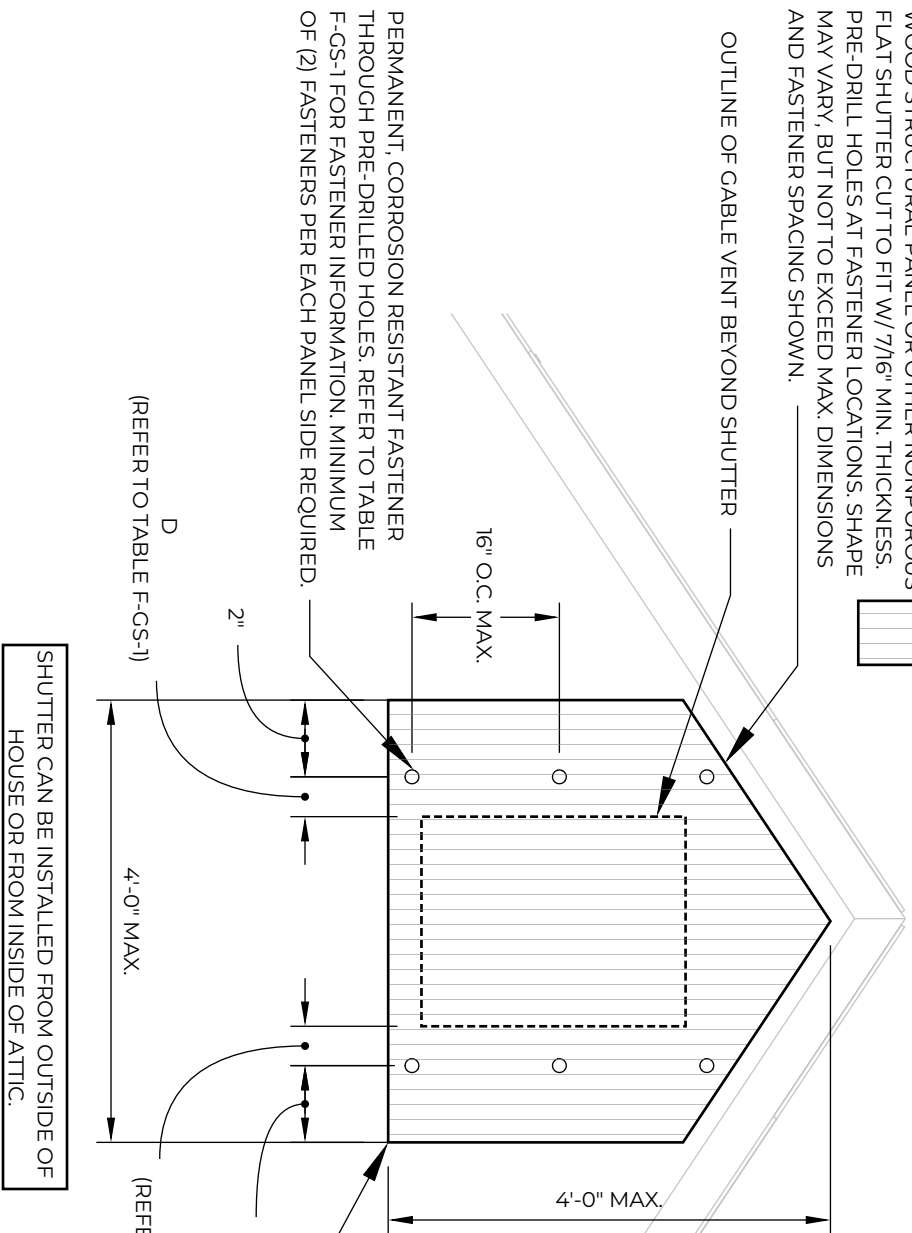

TABLE F-GS-1: FASTENING SCHEDULE FOR CABLE VENT COVER.

SUPPORT STRUCTURE TYPE	FASTENER TYPE & SIZE	END DISTANCE, D
WOOD	1/4" Ø LAG SCREWS W/ 2" EMBEDMENT & 1" Ø WASHER	1"
CONCRETE OR GROUTED MASONRY	1/4" Ø FASTENER W/ 2" EMBEDMENT & 1" Ø WASHER	1.5"

NOTES: WHERE SCREWS ARE ATTACHED TO MASONRY OR MASONRY/STUCCO, USE VIBRATION-RESISTANT ANCHORS W/ 1500 LBS MIN. WITHDRAWAL CAPACITY.

NOTE: SELF-ADHESIVE WEATHER STRIPPING CAN BE USED TO SEAL THE SHUTTERS TO THE TRIM BOARDS AROUND VENT EDGES. IF SHUTTER IS INSTALLED ON INSIDE OF ATTIC, ENSURE THAT ANY WATER THAT ACCUMULATES IN THE CAVITY CAN DRAIN TO THE OUTSIDE OF THE HOUSE AND NOT INTO THE WALL BELOW.

APPLICABLE STANDARDS:

FORTIFIED HOME™ - HURRICANE (2020)

DESCRIPTION:

TEMPORARY CABLE VENT SHUTTERING

DRAWING #:

F-GS-1

DATE:

11/01/2020



- GENERAL NOTES:**
 REFER TO APPLICABLE FORTIFIED HOME STANDARDS FOR ADDITIONAL INFORMATION.
- OVERHANGS CANNOT BE VENTED. FORTIFIED HOME STANDARDS ARE TO BE APPLIED IN CONJUNCTION WITH FEDERAL, STATE, AND LOCAL CODES, ORDINANCES AND REGULATIONS IN ADDITION TO THE STRUCTURAL DESIGN WHICH IS BY OTHERS, IN CASE OF A CONFLICT BETWEEN PROVISIONS, USE WHICHEVER IS MORE STRINGENT.

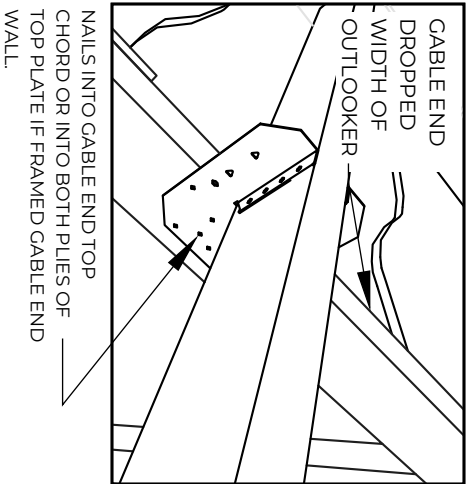

ROOF SHEATHING MIN. 7/16" THICK NAILED PER FORTIFIED REQUIREMENTS.

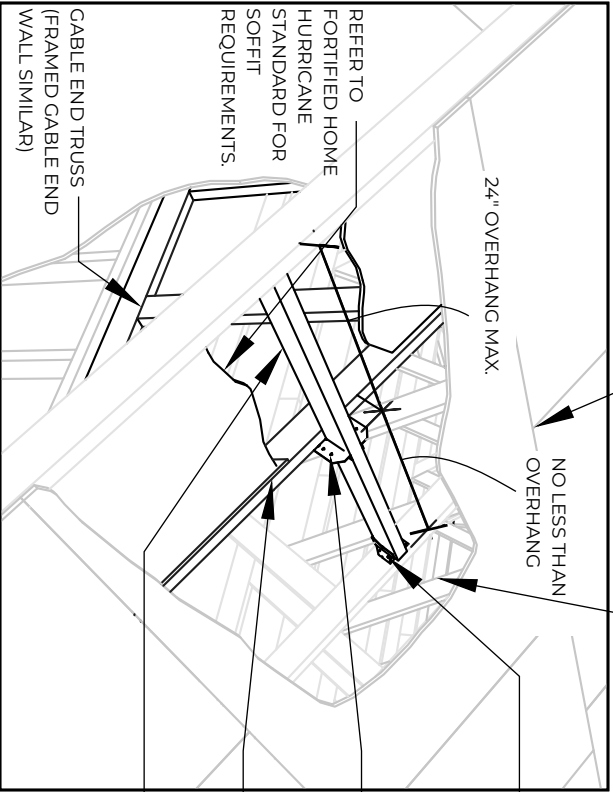

ROOF FRAMING MEMBERS @ MAX 24" O.C., TYP.

- SIMPSON LU24 OR USP J124 JOIST FACE HANGER W/ (4) 0.162 X 3-1/2" NAILS TO TRUSS AND (2) 0.148 X 1-1/2" NAILS TO OUTLOOKER
- SADDLE-TYPE HURRICANE CLIP AT GABLE END. REFER TO TABLE F-GE-1 FOR MINIMUM UPLIFT CONNECTION REQUIREMENTS.
- TOP OF CABLE MUST BE DROPPED WIDTH OF OUTLOOKER
- 2" X 4" CONTINUOUS OUTLOOKER MIN. @ MAX 24" O.C. TYP. OUTLOOKER MUST BE POSITIONED IN EDGEWISE ORIENTATION. (FLATWISE IS NOT ACCEPTABLE).

TABLE F-GE-1: RAKE OVERHANG OUTLOOKER MAXIMUM LENGTH AND CONNECTION REQUIREMENTS.

Ultimate Wind Speed, V_{ult} (mph)	Exposure B&C		Exposure D	
	Max. Overhang Length (in) ¹	Uplift Connection at Gable End ^{1,3,4,5}	Max. Overhang Length (in) ¹	Uplift Connection at Gable End ^{1,3,4,5}
130	24	Simpson H10A USP RT16A	22	Simpson H10A USP RT16A
140	22	Simpson H10A USP RT16A	18	Simpson H10A USP RT16A
150	20	Simpson H10A USP RT16A	16	Simpson H10A USP RT16A
160	16	Simpson H10A USP RT16A	14	Simpson H10A USP RT16A
170	14	Simpson H10A USP RT16A	14	Simpson H14
180	14	Simpson H14	14	Simpson H14

Notes:

- Both outlooker framing spacing and connector spacing are @ 24" O.C. max.
- Loads are per the 2018 Wood Frame Construction Manual and ASCE 7-16.
- Simpson H10A connection requires (9) 0.148 x 1-1/2 nails to outlooker and (9) 0.148 x 1-1/2 nails to gable end top chord.
- USP RT16A connection requires (9) 0.148 x 1-1/2 nails to outlooker and (8) 0.148 x 1-1/2 nails to gable end top chord.
- Simpson H14 connection requires (12) 0.131 x 1-1/2 nails to outlooker and (15) 0.131 x 2-1/2 nail to gable end top chord.

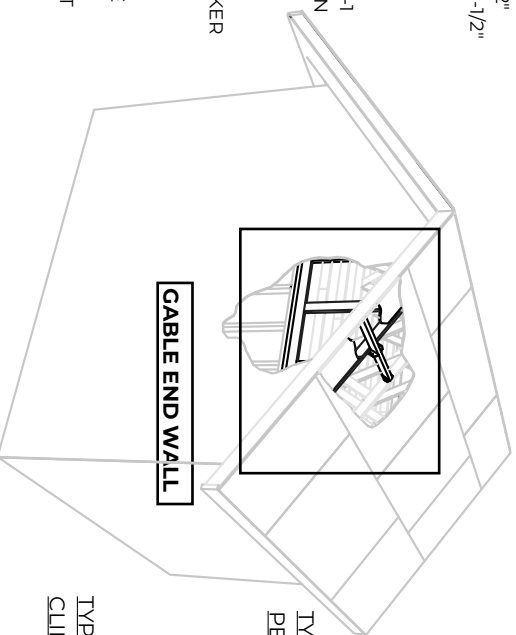

TYPICAL JOIST HANGER PERSPECTIVE VIEW

TYPICAL SADDLE-TYPE CLIP PERSPECTIVE VIEW

APPLICABLE STANDARDS:

FORTIFIED HOME™ - HURRICANE (2020)

DESCRIPTION:

PRESCRIPTIVE CABLE END OUTLOOKER FRAMING AND ANCHORAGE

DRAWING #:

F-GE-1

DATE:

11/01/20



- GENERAL NOTES:**
- REFER TO APPLICABLE FORTIFIED HOME STANDARDS FOR ADDITIONAL INFORMATION. FORTIFIED HOME STANDARDS ARE TO BE APPLIED IN CONJUNCTION WITH FEDERAL, STATE, AND LOCAL CODES, ORDINANCES AND REGULATIONS IN ADDITION TO THE STRUCTURAL DESIGN WHICH IS BY OTHERS. IN CASE OF A CONFLICT BETWEEN PROVISIONS, USE WHICHEVER IS MORE STRINGENT.
 -

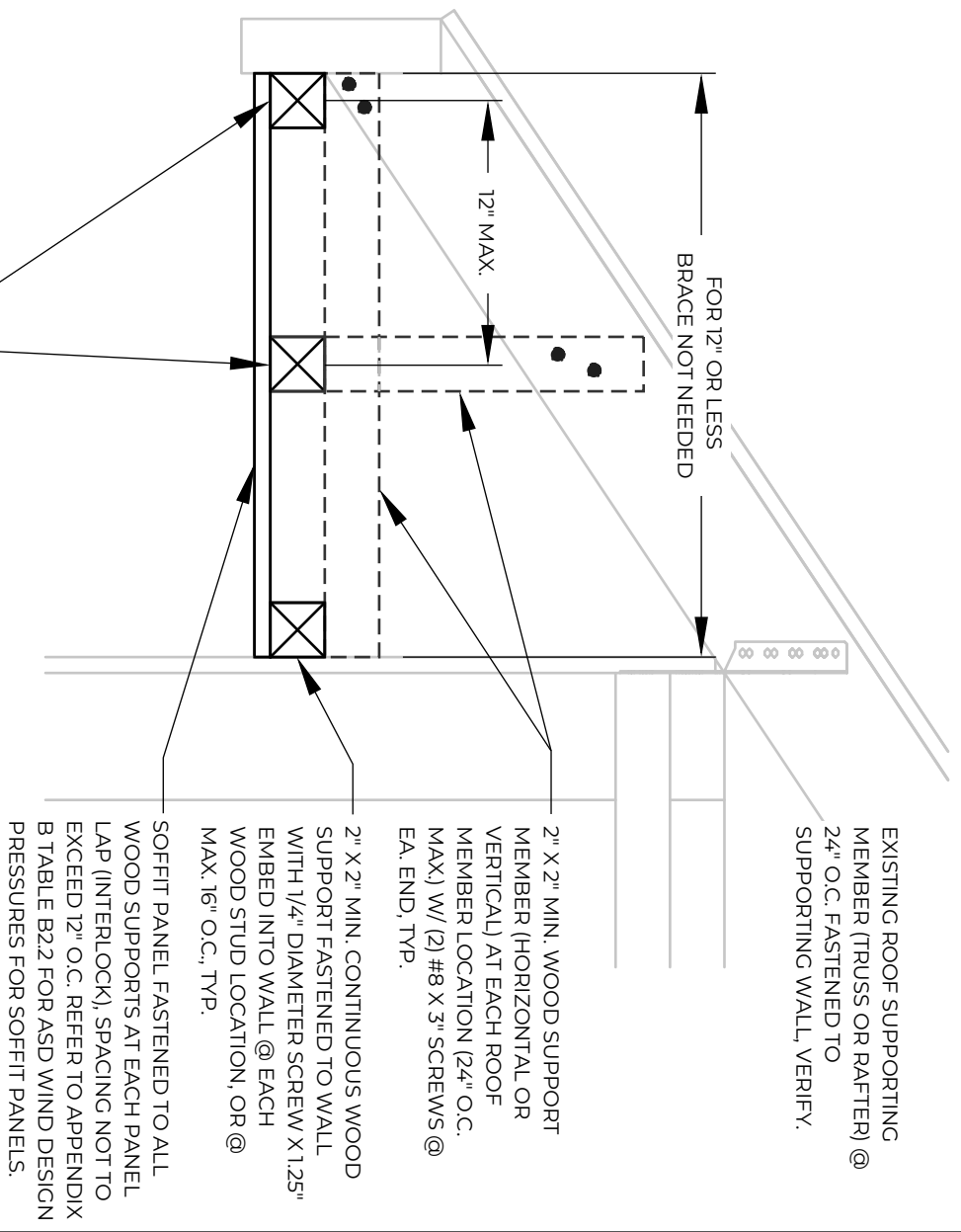
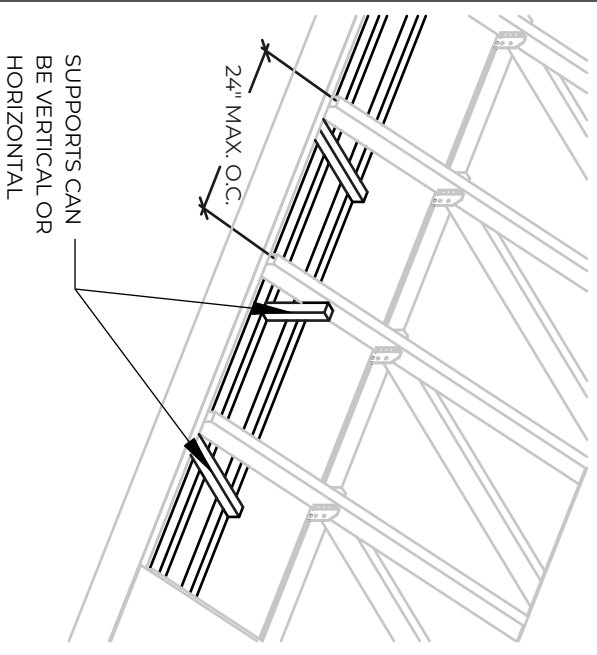

2" X 2" MIN. CONTINUOUS WOOD MEMBER SPACED @ MAX. 12" O.C. FASTENED TO WOOD SUPPORT W/ #8X3" SCREW AT EACH INTERSECTION, TYP.

FASTENERS FOR SOFFIT PANEL MUST BE CORROSION RESISTANT AND MINIMUM ONE OF THE FOLLOWING:
STAPLE 7/16" CROWN X 7/8" LENGTH X 16 GA.
NAIL 6D X 1" EMBEDMENT
SCREW #8 X 1" EMBEDMENT

APPLICABLE STANDARDS:

FORTIFIED HOME™ - HURRICANE (2020)

DESCRIPTION:

SOFFIT RETROFIT DETAIL

DRAWING #:

F-S-1

DATE:

11/01/2020



- GENERAL NOTES:**
 REFER TO APPLICABLE FORTIFIED HOME STANDARDS FOR ADDITIONAL INFORMATION.
- PRESCRIPTIVE RETROFIT GUIDANCE IS APPLICABLE FOR CHIMNEYS LOCATED IN THE INTERIOR ZONE OF THE ROOF (ZONE 1) AND EXTENDING LESS THAN 5 FT ABOVE THE ROOF DECK. ANCHORAGE FOR CHIMNEYS OUTSIDE OF THESE LIMITATIONS REQUIRES ENGINEERING REVIEW AND DETAILING BY A PROFESSIONAL ENGINEER.
 - FORTIFIED HOME STANDARDS ARE TO BE APPLIED IN CONJUNCTION WITH FEDERAL, STATE, AND LOCAL CODES, ORDINANCES AND REGULATIONS IN ADDITION TO THE STRUCTURAL DESIGN WHICH IS BY OTHERS. IN CASE OF A CONFLICT BETWEEN PROVISIONS, USE WHICHEVER IS MORE STRINGENT.
 -

EXTERIOR FULLY SHEATHED WITH 7/16" MIN. WOOD STRUCTURAL PANELS.

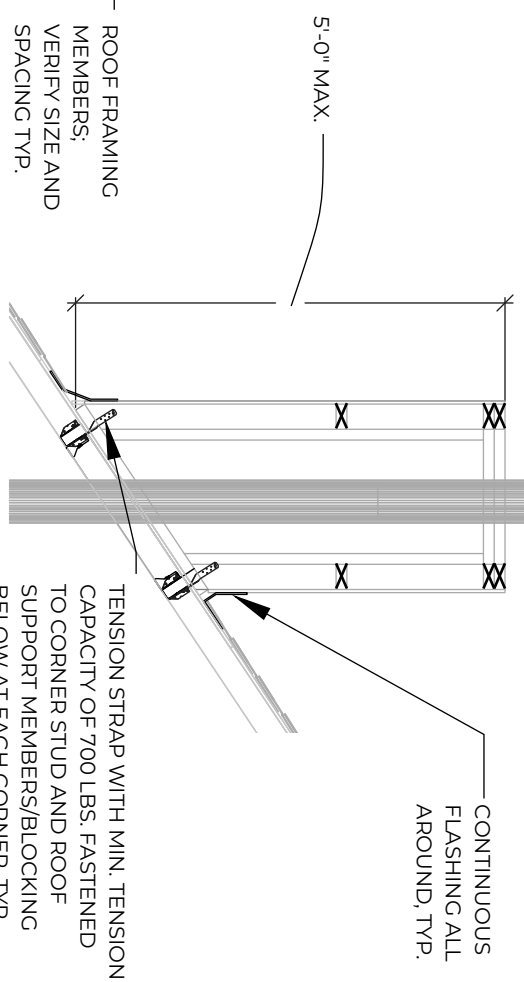
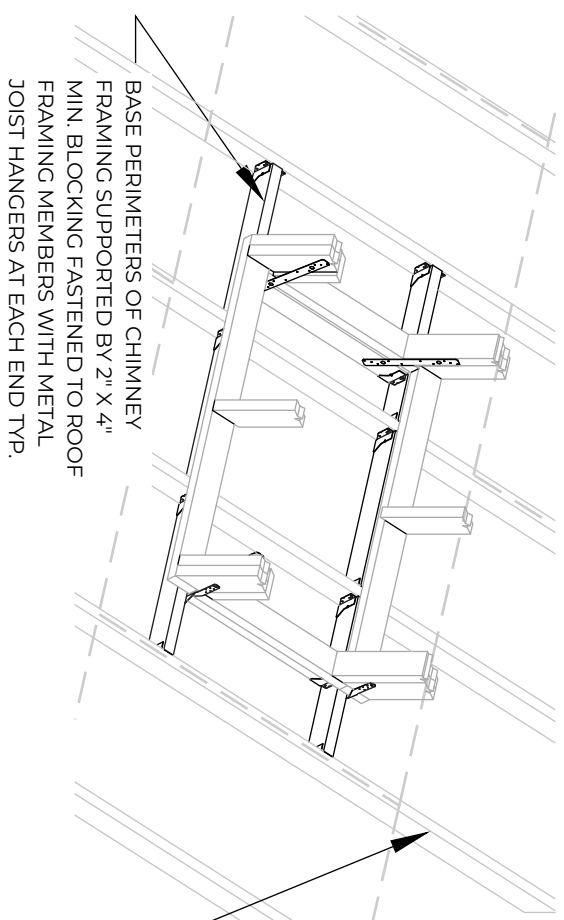
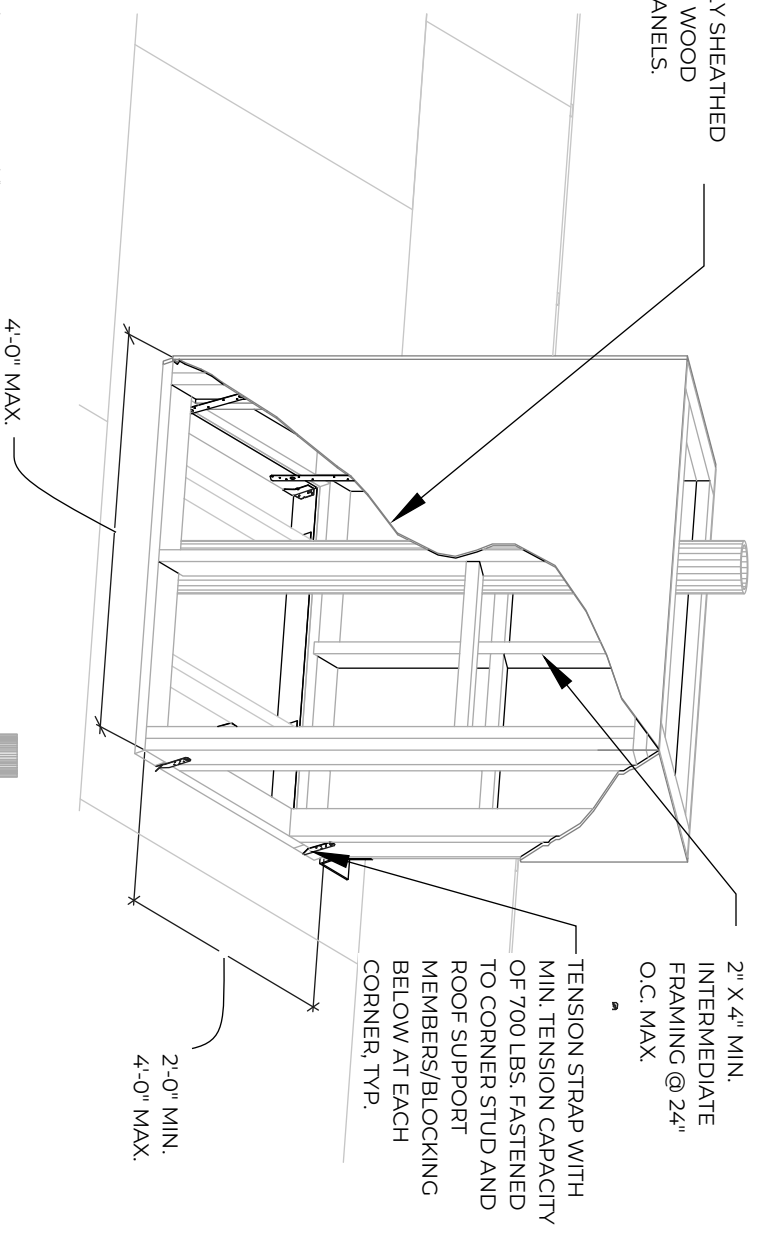

APPLICABLE STANDARDS:

FORTIFIED HOME™ - HURRICANE (2020)
 FORTIFIED HOME™ - HIGH WIND (2020)

DESCRIPTION:

PRESCRIPTIVE CHIMNEY TIE-DOWN
 DETAIL FOR CHIMNEYS UP TO 5 FT

DRAWING #:

F-CTD-1

DATE:

11/01/20

