



STANDARD DETAIL SET

High Wind



2020

FORTIFIED Home™ Standard Details Table of Contents

High Wind Only Set

For Use with 2020 FORTIFIED Home Standard

| Detail Number | Detail Title | Applicable Levels | | |
|---------------|--|-------------------|--------|------|
| | | Roof | Silver | Gold |
| F-G-1 | Corrosion Protection Requirements | ✓ | ✓ | ✓ |
| F-G-2 | Roof and Wall Zone Diagram | ✓ | ✓ | ✓ |
| F-RS-1 | Roof Deck Attachment - Sawn Lumber or Wood Board Roof Deck with No Gaps | ✓ | ✓ | ✓ |
| F-RS-3 | High Wind - New Construction Roof Deck Attachment - Structural Wood Panels | ✓ | ✓ | ✓ |
| F-SRD-1 | Roof Deck Attachment and Sealed Roof Deck from Within Using Spray Foam | ✓ | ✓ | ✓ |
| F-SRD-2 | Steep Slope Sealed Roof Deck - Flashing Tape and Underlayment- Shingle or Metal Roof Covers | ✓ | ✓ | ✓ |
| F-SRD-3 | Steep Slope Sealed Roof Deck - Two Layers Felt Underlayment - Shingle or Metal Roof Covers | ✓ | ✓ | ✓ |
| F-SRD-4 | Steep Slope Sealed Roof Deck - Self-Adhered Membrane (Showing Bond Break for Asphalt Shingles) - Shingle and Metal Roof Covers | ✓ | ✓ | ✓ |
| F-SRD-5 | Steep Slope Sealed Roof Deck - Flashing Tape, Underlayment and Roof Tile Cap Sheet - Concrete and Clay Tile Roof Covers | ✓ | ✓ | ✓ |
| F-SRD-6 | NEW FOR 2020 Steep Slope Sealed Roof Deck - Self-Adhered Membrane - Concrete and Clay Tile Roof Covers | | | |
| F-DE-2 | DISCONTINUED IN 2020 | N/A | N/A | N/A |
| F-DE-3 | High Wind - Drip Edge Installation Over Underlayment | ✓ | ✓ | ✓ |
| F-RC-1 | Asphalt Shingle Installation Guidance for Steep Slope - Option 1: Peel and Stick Starter Strip Installation at Eave or Rake | ✓ | ✓ | ✓ |
| F-RC-2 | Asphalt Shingle Installation Guidance for Steep Slope - Option 2: Shingle Strip Starter Installation at Eave or Rake | ✓ | ✓ | ✓ |
| F-RC-3 | Asphalt Shingle Installation Guidance for Steep Slope - Option 3: Shingles Set Directly in Flashing Cement at Rake Only | ✓ | ✓ | ✓ |
| F-RR-1 | Re-Roofing Deck Replacement Fastening Detail | ✓ | ✓ | ✓ |
| F-RR-2 | Re-Roofing New Scab Member Detail for Damaged or Deteriorated Wood Framing Member | ✓ | ✓ | ✓ |
| F-RR-4 | High Wind - Re-Nailing the Roof Deck (Wood Structural Panels) | ✓ | ✓ | ✓ |
| F-RR-5 | NEW FOR 2020 Fastening Wood Structural Panel Roof Sheathing Over Existing 1x Roo Deck Boards with Gaps | ✓ | ✓ | ✓ |
| F-CTD-1 | NEW FOR 2020 Prescriptive Chimney Tie-Down Detail for Chimneys up to 5 ft | N/A | ✓ | ✓ |

FORTIFIED Home™ Standard Details Naming Convention

FORTIFIED Home™ Standard Detail numbers are comprised of three alphanumeric identifications to provide general categorization:

1. First alphabetic identification – FORTIFIED Detail:
 - F = FORTIFIED

2. Second alphabetic identification – Secondary Category
 - G = General Information
 - RS = Roof Sheathing
 - SRD = Sealed Roof Deck
 - DE = Drip Edge
 - RC = Roof Cover
 - RR = Re-Roof
 - GS = Gable Shuttering
 - GE = Gable End
 - S = Soffit
 - CTD = Chimney Tie Down

3. Numeric identification – chronological order detail was completed

Example: F-RS-1

Fortified Detail → Roof Sheathing Detail → First Detail in this category

FORTIFIED Fastener and Connector Corrosion Protection Requirements

| Fasteners/Connectors | Structures within 300 ft of saltwater | Structures more than 300 ft but less than 1,000 ft from saltwater¹ | Structures more than 1,000 ft but less than 3,000 ft from saltwater | Structures more than 3,000 ft from saltwater |
|---|--|--|--|---|
| Roofing nails for shingles | Stainless steel | Stainless steel | Hot-dip galvanized ⁴ | Corrosion resistant ⁵ |
| Concrete and clay roof tile fasteners | Stainless steel | Stainless steel | Hot-dip galvanized ⁴ | Corrosion resistant ⁵ |
| Metal roof clips and fasteners (exposed) | Stainless steel | Stainless steel | Stainless steel | Corrosion resistant ⁵ |
| Fasteners used for attachment of roof deck to structural roof members | Not required to meet minimum corrosion protection requirements unless required by the local building code or ordinance | | | |
| Fasteners used for attachment of underlayment to roof deck | Hot-dip galvanized ⁴ | Hot-dip galvanized ⁴ | Hot-dip galvanized ⁴ | Corrosion resistant ⁵ |
| Aluminum soffits | Not allowed | Not allowed | Allowed | Allowed |
| Soffit and roof vent fasteners | Stainless steel | Stainless steel | Stainless steel | Corrosion resistant ⁵ |
| Metal framing connectors, fasteners, anchors, and hangers in exposed areas² | Stainless steel | Stainless steel | Stainless steel | Stainless steel or G185 galvanized coating |
| Metal framing connectors, fasteners, anchors, and hangers in vented enclosed areas³ | Stainless steel | Stainless steel or G185 galvanized coating | Stainless steel or G185 galvanized coating | Corrosion resistant ⁵ |

Notes:

- Buildings on open, elevated foundations within 1,000 ft of saltwater shall follow the requirements of structures within 300 ft of saltwater.
- Examples of exposed areas include areas that are under roof overhangs, decks and covered walkways or in any location that is openly or partially exposed to saltwater air.
- Examples of vented enclosed areas include attics with vents.
- Hot-dip galvanized shall meet the requirements of ASTM A153, Class D for nails and screws.
- Corrosion-resistant nails and screws shall meet the requirements of ASTM A 641, Class 1, or an equal corrosion resistance by coating, galvanization, stainless steel, or other suitable corrosion-resistant material. Corrosion-resistant sheet metal connectors, anchors, and hangers shall meet the requirements of ASTM A653, G90.



APPLICABLE STANDARDS:

FORTIFIED HOME™ - HURRICANE (2020)
 FORTIFIED HOME™ - HIGH WIND (2020)

DESCRIPTION:

CORROSION PROTECTION
 REQUIREMENTS

DRAWING #:

F-G-1

DATE:

11/01/2020

INTERIOR ZONES
ROOFS - ZONE 1/ WALLS - ZONE 4

END ZONES
ROOFS - ZONE 2/ WALLS - ZONE 5

CORNER ZONES
ROOFS - ZONE 3

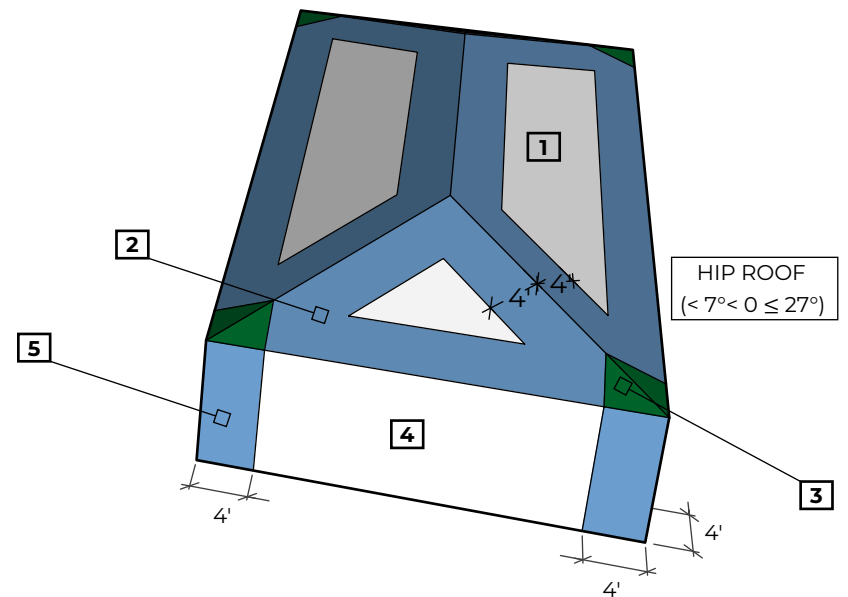
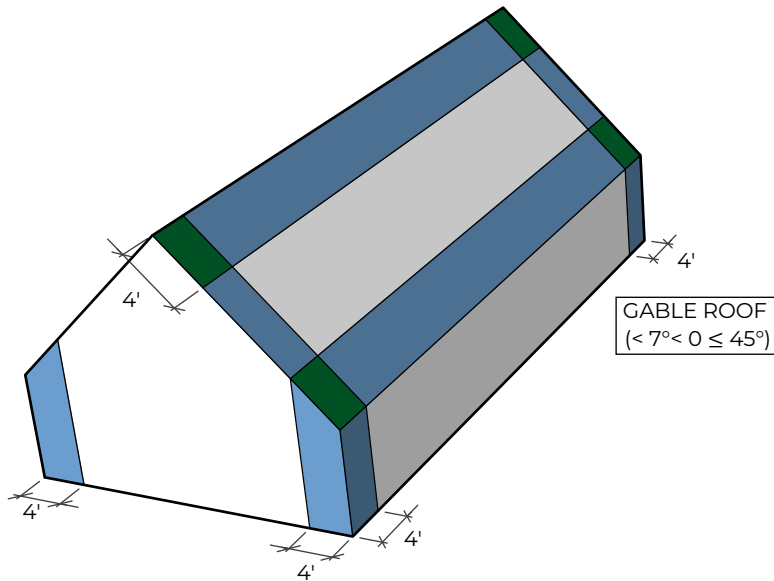
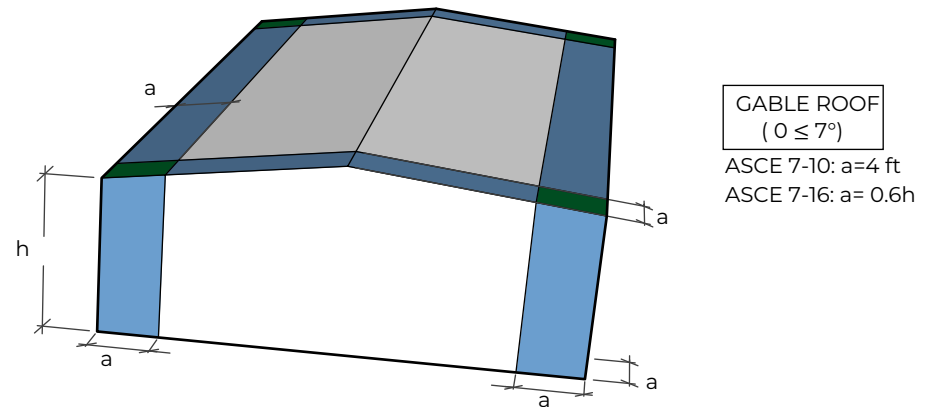
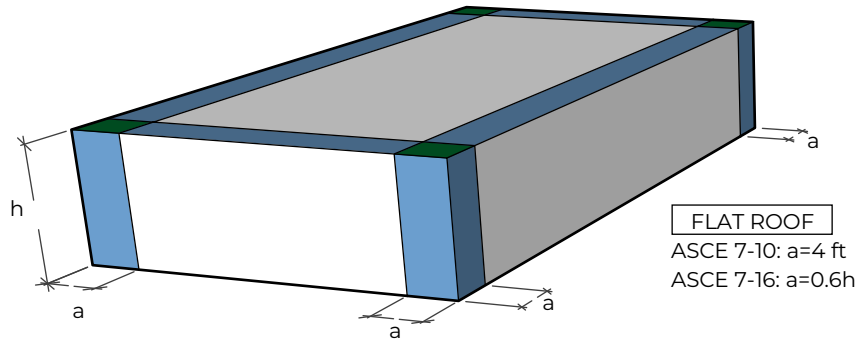

GENERAL NOTES:

1. REFER TO APPLICABLE FORTIFIED HOME STANDARDS FOR ADDITIONAL INFORMATION.
2. FORTIFIED HOME STANDARDS ARE TO BE APPLIED IN CONJUNCTION WITH FEDERAL, STATE, AND LOCAL CODES, ORDINANCES AND REGULATIONS IN ADDITION TO THE STRUCTURAL DESIGN WHICH IS BY OTHERS. IN CASE OF A CONFLICT BETWEEN PROVISIONS, USE WHICHEVER IS MORE STRINGENT.



APPLICABLE STANDARDS:

FORTIFIED HOME™ - HURRICANE (2020)
FORTIFIED HOME™ - HIGH WIND (2020)

DESCRIPTION:

ROOF AND WALL ZONE DIAGRAM

DRAWING #:

F-G-2

DATE:

11/01/2020

GENERAL NOTES:

1. REFER TO APPLICABLE FORTIFIED HOME STANDARDS FOR ADDITIONAL INFORMATION.
2. APPLICABLE FOR SHINGLE OR METAL ROOF COVERS.
3. FORTIFIED HOME STANDARDS ARE TO BE APPLIED IN CONJUNCTION WITH FEDERAL, STATE, AND LOCAL CODES, ORDINANCES AND REGULATIONS IN ADDITION TO THE STRUCTURAL DESIGN WHICH IS BY OTHERS. IN CASE OF A CONFLICT BETWEEN PROVISIONS, USE WHICHEVER IS MORE STRINGENT.

REFER TO TABLE F-RS-1 FOR REQUIRED SIZE AND NUMBER OF NAILS.

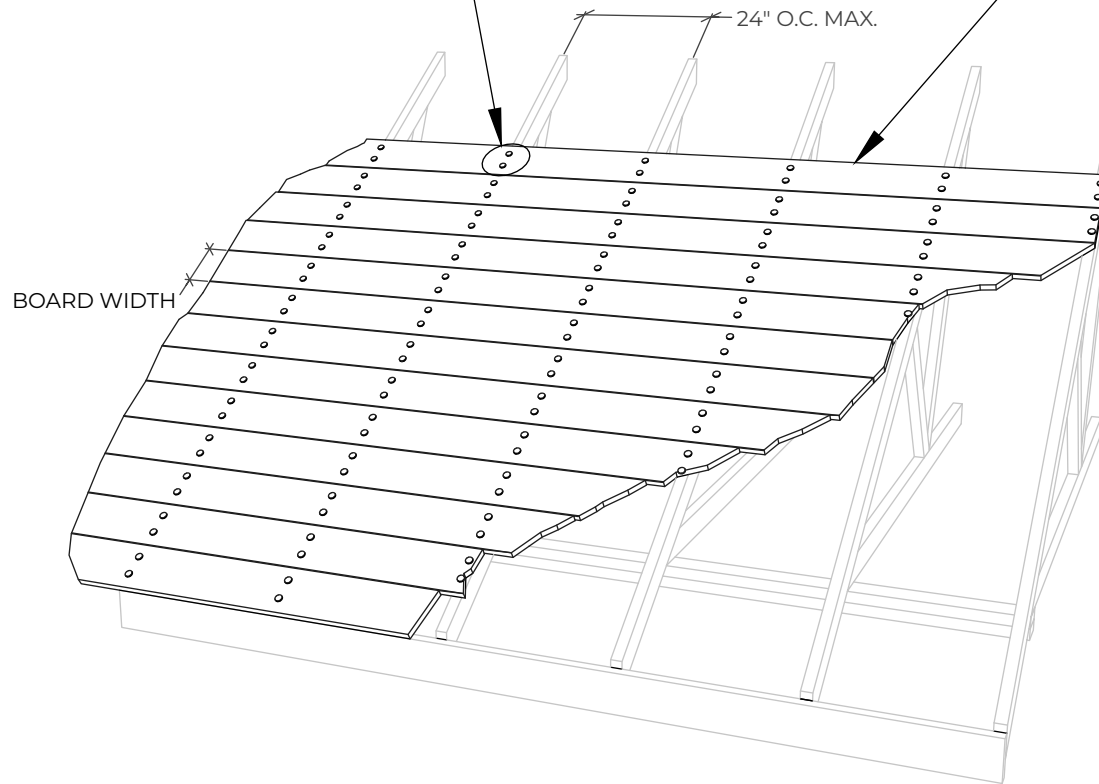

MINIMUM 5/8" SAWN LUMBER OR WOOD BOARD ROOF DECK BY OTHERS.

ROOF FRAMING MEMBERS W/ 2" MIN. NOMINAL THICKNESS.

Table F-RS-1: FASTENERS REQUIRED FOR WOOD BOARD DECKING ATTACHMENT.

| WOOD BOARD/LUMBER (ROOF DECKING) WIDTH | NUMBER AND MINIMUM DIMENSIONS OF NAILS PER BOARD FOR EACH FRAMING MEMBER IT CROSSES |
|--|--|
| UP TO 8". | TWO(2) 0.131" Ø MIN. W/ 1 - 5/8" PENETRATION INTO ROOF FRAMING MEMBERS (MIN. LENGTH OF NAIL= 2 - 1/2") |
| LARGER THAN 8". | THREE(3) 0.131" Ø MIN. W/ 1 - 5/8" PENETRATION INTO ROOF FRAMING MEMBERS (MIN. LENGTH OF NAIL= 2 - 1/2") |

NOTE: CLIPPED-HEAD, D-HEAD, OR ROUND-HEAD NAILS SHALL BE ACCEPTABLE PROVIDED THEY HAVE THE REQUIRED MINIMUM DIAMETER AND LENGTH .



APPLICABLE STANDARDS:

FORTIFIED HOME™ - HURRICANE (2020)
 FORTIFIED HOME™ - HIGH WIND (2020)

DESCRIPTION:

ROOF DECK ATTACHMENT - SAWN LUMBER OR WOOD BOARD ROOF DECK WITH NO GAPS

DRAWING #:

F-RS-1

DATE:

11/01/2020

GENERAL NOTES:

1. REFER TO APPLICABLE FORTIFIED HOME STANDARDS FOR ADDITIONAL INFORMATION.
2. TO BE ELIGIBLE FOR GOLD DESIGNATION, ROOF MEMBERS MUST BE DESIGNED FOR MINIMUM Vult = 130 MPH DESIGN WIND LOADS AND TERRAIN EXPOSURE C.
3. FORTIFIED HOME STANDARDS ARE TO BE APPLIED IN CONJUNCTION WITH FEDERAL, STATE, AND LOCAL CODES, ORDINANCES AND REGULATIONS IN ADDITION TO THE STRUCTURAL DESIGN WHICH IS BY OTHERS. IN CASE OF A CONFLICT BETWEEN PROVISIONS, USE WHICHEVER IS MORE STRINGENT.

Table F-RS-3: MINIMUM REQUIREMENTS FOR ROOF SHEATHING THICKNESS AND FASTENING

| ASCE Edition | Minimum Roof Sheathing Thickness ^{1,2,3} | | | | Minimum Nail Size/Type ^{1,4} | Maximum Nail Spacing (All Roof Areas) ¹ |
|--------------|---|-----------------------------------|-----------------------------------|-----------------------------------|--|--|
| | Roof members @ 16" O.C. Max. | | Roof Members @ 24" O.C. Max. | | | |
| | FORIFIED Levels: Roof and Silver | FORTIFIED Level: Gold | FORIFIED Levels: Roof and Silver | FORTIFIED Level: Gold | | |
| ASCE 7-10 | 3/8" <i>See Notes 1, 2, 3</i> | 7/16" <i>See Notes 1, 2, 3</i> | 7/16" <i>See Notes 1, 2, 3</i> | 7/16" <i>See Notes 1, 2, 3</i> | RSRS-01; 0.113" dia. x 2-3/8" Roof Sheathing Ring Shank Nail | 6" O.C. |
| | | | | | 8d Common Nail; 0.131" dia. X 2-1/2" | 4" O.C. |
| ASCE 7-16 | 3/8" <i>See Notes 1, 2, 3</i> | 7/16" <i>See Notes 1, 2, 3</i> | 15/32" <i>See Notes 1, 3</i> | 15/32" <i>See Notes 1, 3</i> | RSRS-01; 0.113" dia. x 2-3/8" Roof Sheathing Ring Shank Nail | 4" O.C. |
| | | | | | Common Nails <i>Not an Option</i> | N/A |

Notes:

1. Local building code requirements for sheathing thickness and/or nail size/attachment spacing may be more stringent based on site conditions.
2. For concrete and clay tile roof covers, minimum required sheathing thickness is 15/32".
3. For metal roof covers, verify manufacturer's sheathing thickness requirements are met.
4. Full round head Ø; No clipped-head nails, common nails or staples shall be allowed. Refer to Figure 1.

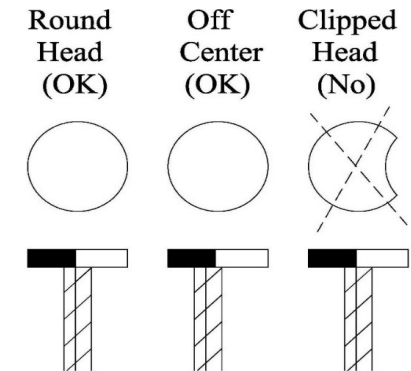
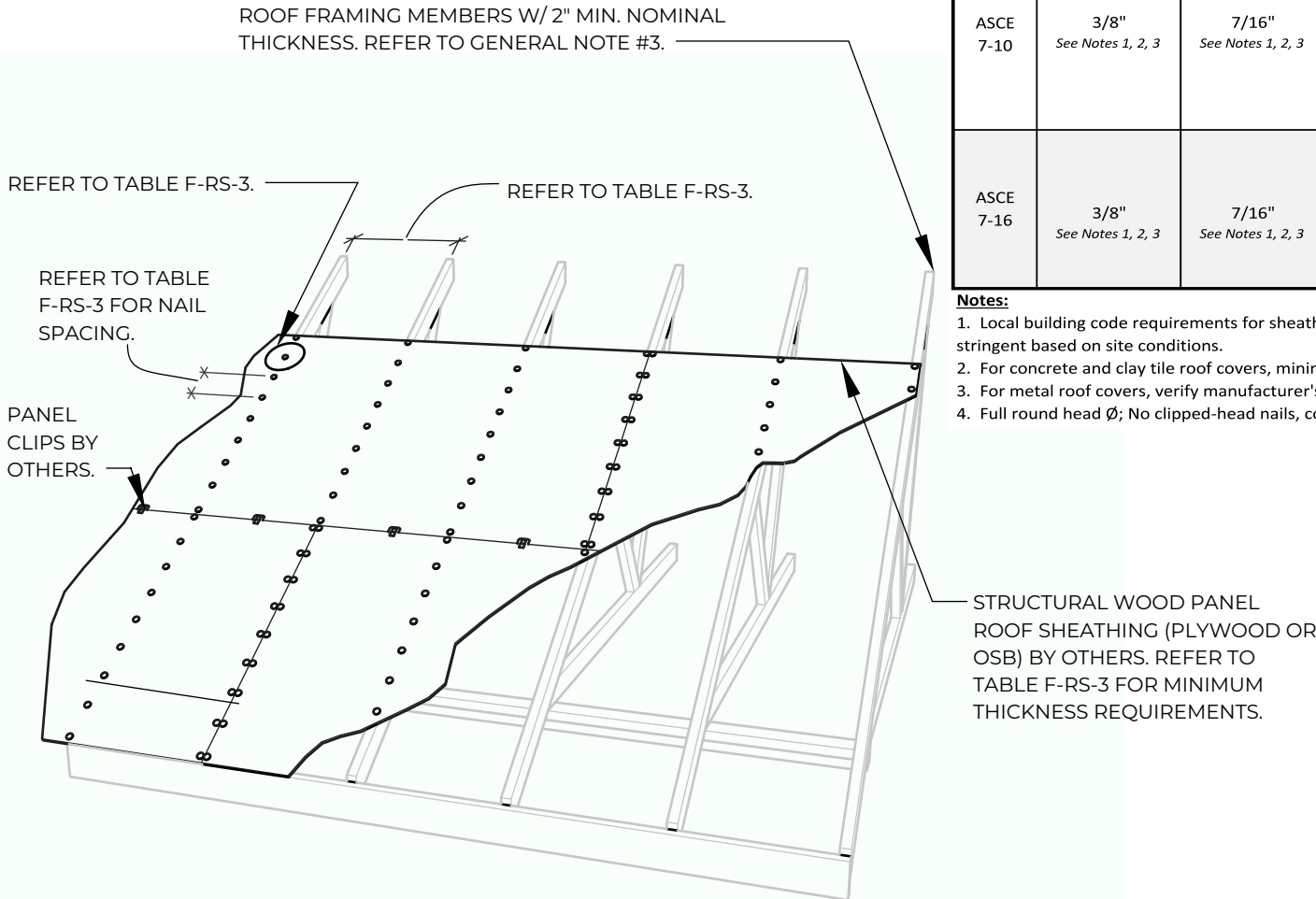

FIGURE 1.



APPLICABLE STANDARDS:

FORTIFIED HOME™ - HIGH WIND (2020)

DESCRIPTION:

HIGH WIND - NEW CONSTRUCTION
ROOF DECK ATTACHMENT -
STRUCTURAL WOOD PANELS

DRAWING #:

F-RS-3

DATE:

11/01/2020

MINIMUM REQUIREMENTS FOR SPRAY ADHESIVES:

1. PRODUCT MUST BE TESTED AND EVALUATED IN ACCORDANCE WITH EITHER ASTM E330, STANDARD TEST METHOD FOR STRUCTURAL PERFORMANCE OF EXTERIOR WINDOWS, DOORS, SKYLIGHTS, AND CURTAIN WALLS BY UNIFORM STATIC AIR PRESSURE DIFFERENCE (APPLIED TO ROOF SHEATHING) OR TAS 202-94, CRITERIA FOR TESTING IMPACT AND NON-IMPACT RESISTANT BUILDING ENVELOPE COMPONENTS USING UNIFORM STATIC AIR PRESSURE. THE MINIMUM ALLOWABLE DESIGN UPLIFT PRESSURE MUST BE GREATER THAN OR EQUAL TO 110 PSF AND THE PROOF TEST PRESSURE ACHIEVED WITHOUT FAILURE OR STRUCTURAL DISTRESS MUST BE GREATER THAN OR EQUAL TO 165 PSF.
2. ADHESIVE MUST BE A TWO-COMPONENT SPRAY POLYURETHANE FOAM SYSTEM WITH A MINIMUM CORE DENSITY OF 1.5-3.0 PCF IN ACCORDANCE WITH ASTM D1622, STANDARD TEST METHOD FOR APPARENT DENSITY OF RIGID CELLULAR PLASTICS.
3. SPRAY POLYURETHANE FOAM ADHESIVE SYSTEM MUST BE INSTALLED BY A PROPERLY TRAINED AND QUALIFIED APPLICATOR IN ACCORDANCE WITH THE MANUFACTURER'S MAINTENANCE AND INSTALLATION GUIDELINES.
4. DOCUMENTATION FROM THE INSTALLING CONTRACTOR, ON COMPANY LETTERHEAD, IDENTIFYING THE MANUFACTURER AND PRODUCT USED FOR THE IMPROVED ROOF SHEATHING ATTACHMENT/SEALED ROOF DECK MUST BE PROVIDED TO THE CERTIFIED FORTIFIED EVALUATOR TO BE INCLUDED WITH FINAL DESIGNATION CHECKLIST. DOCUMENTATION SHOULD ALSO STATE THAT THE INSTALLATION MEETS THE MANUFACTURER'S REQUIREMENTS FOR AN ALLOWABLE DESIGN UPLIFT PRESSURE OF AT LEAST 110 PSF (PROOF TEST OF AT LEAST 165 PSF).
5. **USE THE MINIMUM DENSITY AND INSTALLATION REQUIREMENTS PRESCRIBED BY THE MANUFACTURER TO MEET A MINIMUM DESIGN UPLIFT PRESSURE ON THE SHEATHING OF 110 PSF FOR HURRICANE OR 80 PSF FOR HIGH WIND.**

GENERAL NOTES:

1. REFER TO APPLICABLE FORTIFIED HOME STANDARDS FOR ADDITIONAL INFORMATION.
2. EXISTING SHEATHING REQUIREMENTS:
FOR HURRICANE: 7/16" MIN. THICKNESS REQUIRED WITH ROOF MEMBERS @ 24" O.C. MAX.
FOR HIGH WIND: 7/16" MIN. THICKNESS IS REQUIRED FOR GOLD DESIGNATION. FOR ROOF/SILVER DESIGNATION, 3/8" MIN. THICKNESS IS PERMITTED WHEN ROOF MEMBERS ARE 16" O.C. MAX.
3. FORTIFIED HOME STANDARDS ARE TO BE APPLIED IN CONJUNCTION WITH FEDERAL, STATE, AND LOCAL CODES, ORDINANCES AND REGULATIONS IN ADDITION TO THE STRUCTURAL DESIGN WHICH IS BY OTHERS. IN CASE OF A CONFLICT BETWEEN PROVISIONS, USE WHICHEVER IS MORE STRINGENT.

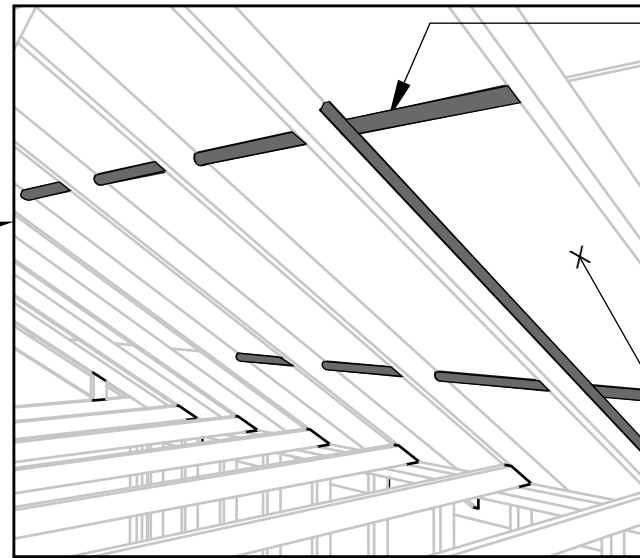
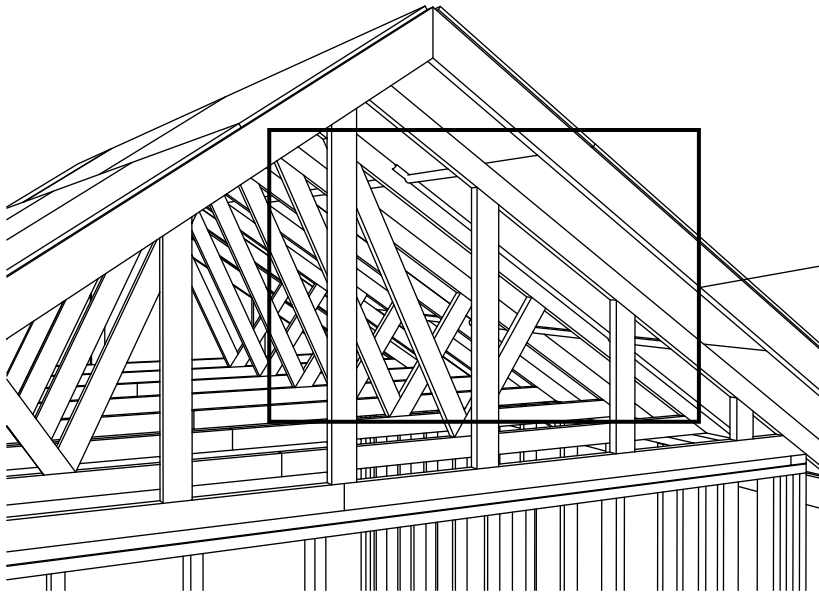

1.5" TO 3" FILLET OF 2-PART SPRAY-APPLIED CLOSED CELL POLYURETHANE FOAM ADHESIVE AT ALL JOINTS BETWEEN SHEATHING AND AT ALL INTERSECTIONS BETWEEN ROOF SHEATHING AND ROOF FRAMING MEMBERS, AND AT ALL VALLEYS. REFER TO MINIMUM REQUIREMENTS FOR SPRAY ADHESIVES.

EXISTING STRUCTURAL WOOD PANEL ROOF SHEATHING BY OTHERS. REFER TO GENERAL NOTE #2 FOR REQUIREMENTS.

UNDERSIDE OF ROOF DECK FROM WITHIN ATTIC



APPLICABLE STANDARDS:

FORTIFIED HOME™ - HURRICANE (2020)
 FORTIFIED HOME™ - HIGH WIND (2020)

DESCRIPTION:

STEEP SLOPE ROOF DECK ATTACHMENT AND SEALED ROOF DECK FROM WITHIN USING SPRAY FOAM

DRAWING #:

F-SRD-1

DATE:

11/01/2020

GENERAL NOTES:

1. REFER TO APPLICABLE FORTIFIED HOME STANDARDS FOR ADDITIONAL INFORMATION.
2. REFER TO FORTIFIED STANDARD DETAIL F-G-1 FOR CORROSION PROTECTION REQUIREMENTS.
3. APPLICABLE FOR ROOF PITCH 2:12 OR GREATER.
4. NAILS USED TO ATTACH UNDERLAYMENT SHALL BE ANNULAR RING OR DEFORMED SHANK ROOFING NAILS W/ 0.083" MINIMUM DIAMETER AND SUFFICIENT LENGTH TO PENETRATE THROUGH THE ROOF SHEATHING OR NOT LESS THAN 3/4" INTO THE ROOF SHEATHING W/ 1" DIAMETER BUTTON CAPS (METAL BUTTON CAPS ARE REQUIRED FOR ULTIMATE DESIGN WIND SPEED OF 160 MPH OR GREATER).
5. FORTIFIED HOME STANDARDS ARE TO BE APPLIED IN CONJUNCTION WITH FEDERAL, STATE, AND LOCAL CODES, ORDINANCES AND REGULATIONS IN ADDITION TO THE STRUCTURAL DESIGN WHICH IS BY OTHERS. IN CASE OF A CONFLICT BETWEEN PROVISIONS, USE WHICHEVER IS MORE STRINGENT.

FLASHING TAPE AT ALL PANEL SEAMS FULLY ADHERED W/ NO WRINKLES OR VOIDS USING ROLLER.

MATERIAL OPTION 1: 4" WIDE ASTM D1970 COMPLIANT SELF-ADHERING POLYMER - MODIFIED BITUMEN FLASHING TAPE.

MATERIAL OPTION 2: 3 - 3/4" WIDE AAMA 711-13 LEVEL 3 (FOR EXPOSURE UP TO 80°C/176°F) COMPLIANT SELF-ADHERING FLASHING TAPE.

ASTM D226 TYPE II #30 OR ASTM D4869 TYPE III OR TYPE IV #30 UNDERLAYMENT. (FOR ASPHALT SHINGLE ROOF COVERS, ASTM D6757 UNDERLAYMENT IS ALSO ACCEPTABLE)

ALT: REINFORCED SYNTHETIC ROOF UNDERLAYMENT WITH ICC APPROVAL AS ASTM D226 TYPE II ;

MINIMUM TEAR STRENGTH = 15 LBF PER ASTM D4533
 MINIMUM TENSILE STRENGTH = 20 PSF PER ASTM D5035
 PASS ASTM D4869 SHOWER TEST.
 HORIZONTAL LAPS = 4" MIN.
 END LAPS = 6" MIN.

HOLD BACK BUTTON CAPS AT EDGES TO AVOID INSTALLING DRIP EDGE OVER BUTTON CAPS. REFER TO F-DE-1 AND/OR F-DE-3 FOR DRIP EDGE INSTALLATION.

ROOF SHEATHING ; REFER TO FORTIFIED STANDARD DETAILS F-RS-1, F-RS-2, AND F-RS-3.

6" MIN. OVERLAP FOLDED OVER RIDGE ON BOTH SIDES.

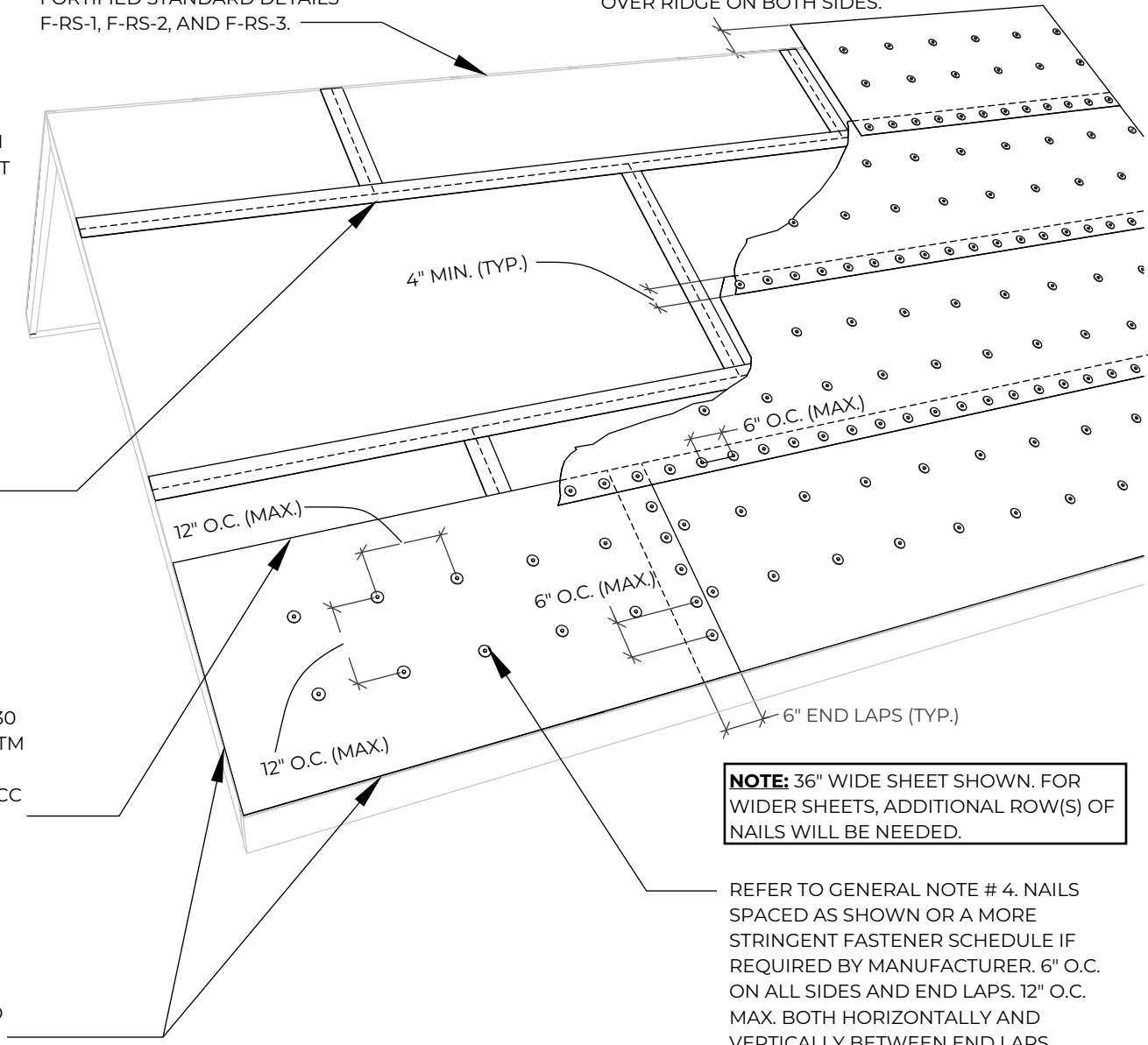

NOTE: 36" WIDE SHEET SHOWN. FOR WIDER SHEETS, ADDITIONAL ROW(S) OF NAILS WILL BE NEEDED.

REFER TO GENERAL NOTE # 4. NAILS SPACED AS SHOWN OR A MORE STRINGENT FASTENER SCHEDULE IF REQUIRED BY MANUFACTURER. 6" O.C. ON ALL SIDES AND END LAPS. 12" O.C. MAX. BOTH HORIZONTALLY AND VERTICALLY BETWEEN END LAPS.



APPLICABLE STANDARDS:

- FORTIFIED HOME™ - HURRICANE (2020)
- FORTIFIED HOME™ - HIGH WIND (2020)

DESCRIPTION:

STEEP SLOPE SEALED ROOF DECK - FLASHING TAPE AND UNDERLAYMENT - SHINGLE OR METAL ROOF COVERS

DRAWING #:

F-SRD-2

DATE:

11/01/2020

GENERAL NOTES:

1. REFER TO APPLICABLE FORTIFIED HOME STANDARDS FOR ADDITIONAL INFORMATION.
2. REFER TO FORTIFIED STANDARD DETAIL F-G-1 FOR CORROSION PROTECTION REQUIREMENTS.
3. WEAVE UNDERLAYMENT ACROSS VALLEYS.
4. DOUBLE LAP UNDERLAYMENT ACROSS RIDGES (UNLESS THERE IS A CONTINUOUS RIDGE VENT).
5. LAP UNDERLAYMENT WITH MINIMUM 6" LEG "TURNED UP" AT WALL INTERSECTIONS; LAP WALL WEATHER BARRIER OVER TURNED-UP ROOF UNDERLAYMENT.
6. APPLICABLE FOR ROOF PITCH 2:12 OR GREATER.
7. NAILS USED TO ATTACH UNDERLAYMENT SHALL BE ANNULAR RING OR DEFORMED SHANK ROOFING NAILS W/ 0.083" MINIMUM DIAMETER AND SUFFICIENT LENGTH TO PENETRATE THROUGH THE ROOF SHEATHING OR NOT LESS THAN 3/4" INTO THE ROOF SHEATHING W/ 1" DIAMETER BUTTON CAPS (METAL BUTTON CAPS ARE REQUIRED FOR ULTIMATE DESIGN WIND SPEED OF 160 MPH OR GREATER.)
8. FORTIFIED HOME STANDARDS ARE TO BE APPLIED IN CONJUNCTION WITH FEDERAL, STATE, AND LOCAL CODES, ORDINANCES AND REGULATIONS IN ADDITION TO THE STRUCTURAL DESIGN WHICH IS BY OTHERS. IN CASE OF A CONFLICT BETWEEN PROVISIONS, USE WHICHEVER IS MORE STRINGENT.

ROOF SHEATHING BY OTHERS ; REFER TO FORTIFIED STANDARD DETAILS F-RS-1, F-RS-2, AND F-RS-3.

ASTM D226 TYPE II #30 OR ASTM D4869 TYPE III OR TYPE IV #30 UNDERLAYMENT LAPPED AS SHOWN. (FOR ASPHALT SHINGLE ROOF COVERS, ASTM D6757 UNDERLAYMENT IS ALSO ACCEPTABLE)

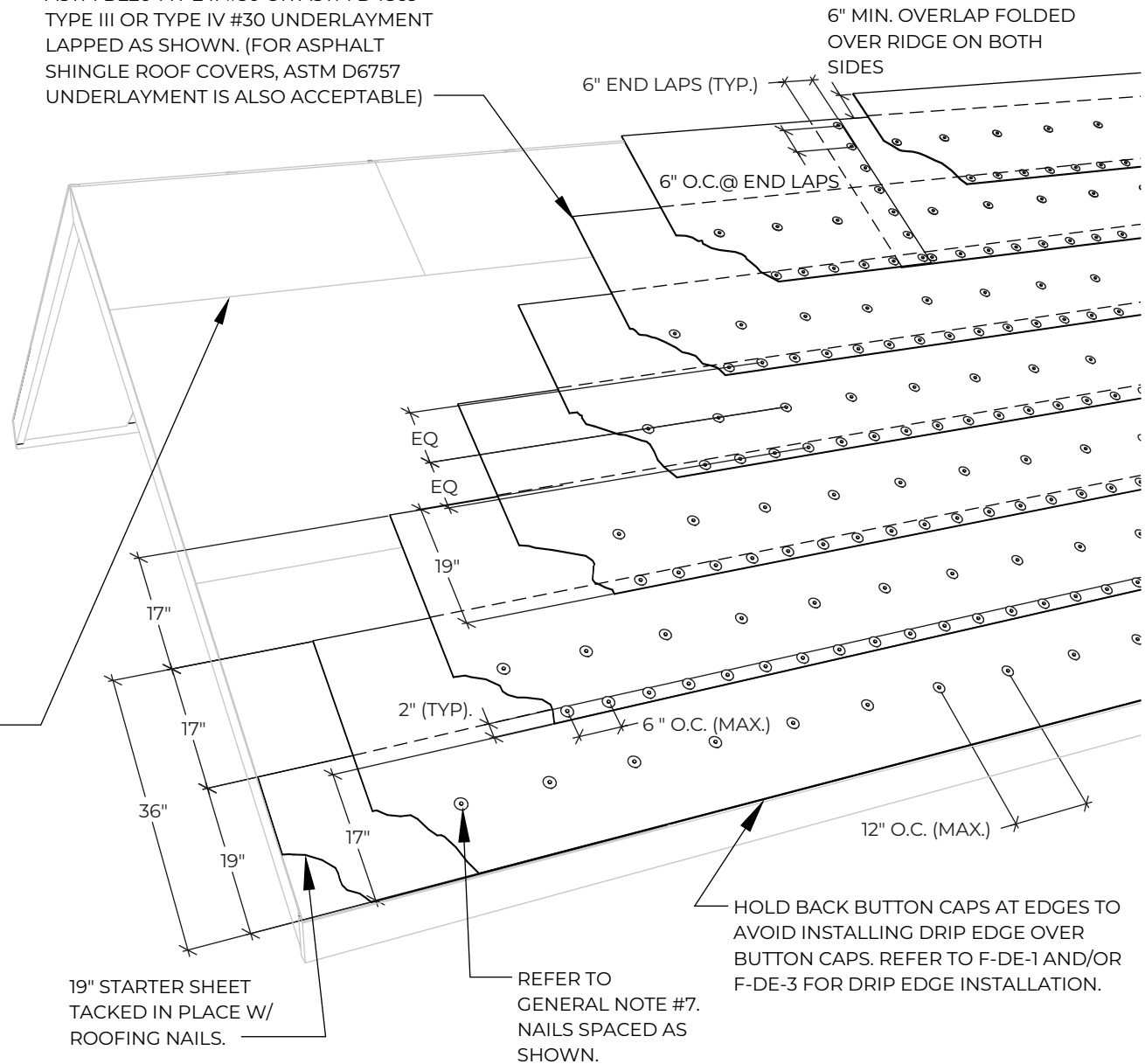

APPLICABLE STANDARDS:

FORTIFIED HOME™ - HURRICANE (2020)
 FORTIFIED HOME™ - HIGH WIND (2020)

DESCRIPTION:

STEEP SLOPE SEALED ROOF DECK -
 TWO LAYERS FELT UNDERLAYMENT -
 SHINGLE OR METAL ROOF COVERS

DRAWING #:

F-SRD-3

DATE:

11/01/2020

GENERAL NOTES:

1. REFER TO APPLICABLE FORTIFIED HOME STANDARDS FOR ADDITIONAL INFORMATION.
2. APPLICABLE FOR ROOF PITCH 2:12 OR GREATER.
3. REFER TO AND INSTALL IN ACCORDANCE WITH MANUFACTURER SPECIFICATIONS AND INSTALLATION INSTRUCTIONS. REFER TO PRODUCT APPROVAL TO VERIFY REQUIRED WIND PRESSURES ARE MET IF APPLICABLE.
4. ADEQUATE ATTIC VENTILATION IS REQUIRED. REFER TO UNDERLAYMENT AND PRIMARY ROOF SYSTEM MANUFACTURER'S INSTALLATION INSTRUCTIONS FOR VENTILATION LIMITATIONS. ALSO CHECK WITH LOCAL BUILDING CODES FOR RESTRICTIONS.
5. FORTIFIED HOME STANDARDS ARE TO BE APPLIED IN CONJUNCTION WITH FEDERAL, STATE, AND LOCAL CODES, ORDINANCES AND REGULATIONS IN ADDITION TO THE STRUCTURAL DESIGN WHICH IS BY OTHERS. IN CASE OF A CONFLICT BETWEEN PROVISIONS, USE WHICHEVER IS MORE STRINGENT.

ROOF SHEATHING; REFER TO FORTIFIED STANDARD DETAILS F-RS-1, F-RS-2, AND F-RS-3. APPLY MANUFACTURER-SPECIFIED COMPATIBLE PRIMER TO ROOF SHEATHING PER MANUFACTURER INSTALLATION INSTRUCTIONS.

4" MIN. SIDELAPS OR GREATER IF SPECIFIED BY MANUFACTURER'S SPECIFICATIONS AND INSTALLATION INSTRUCTIONS.

8"

8"

REFER TO F-DE-1 AND/OR F-DE-3 FOR DRIP EDGE INSTALLATION.

ASTM D1970 SELF-ADHERING POLYMER-MODIFIED BITUMEN MEMBRANE COVERING ENTIRE ROOF DECK. REFER TO GENERAL NOTES #3 AND #4.

REFER TO MANUFACTURER'S SPECIFICATIONS FOR REQUIRED OVERLAP AND FOLLOW INSTALLATION INSTRUCTIONS.

STAGGER AND INSTALL END LAPS AS SPECIFIED PER MANUFACTURER'S SPECIFICATIONS AND INSTALLATION INSTRUCTIONS.

OPTIONAL FOR ASPHALT SHINGLES, APPLY #15 ASTM D226 TYPE I UNDERLYMENT AS BOND BREAK HELD BACK 8" FROM ROOF EDGES OVER ENTIRE ROOF.

FASTENED ADEQUATELY TO KEEP IN PLACE UNTIL ROOF COVERING IS APPLIED.

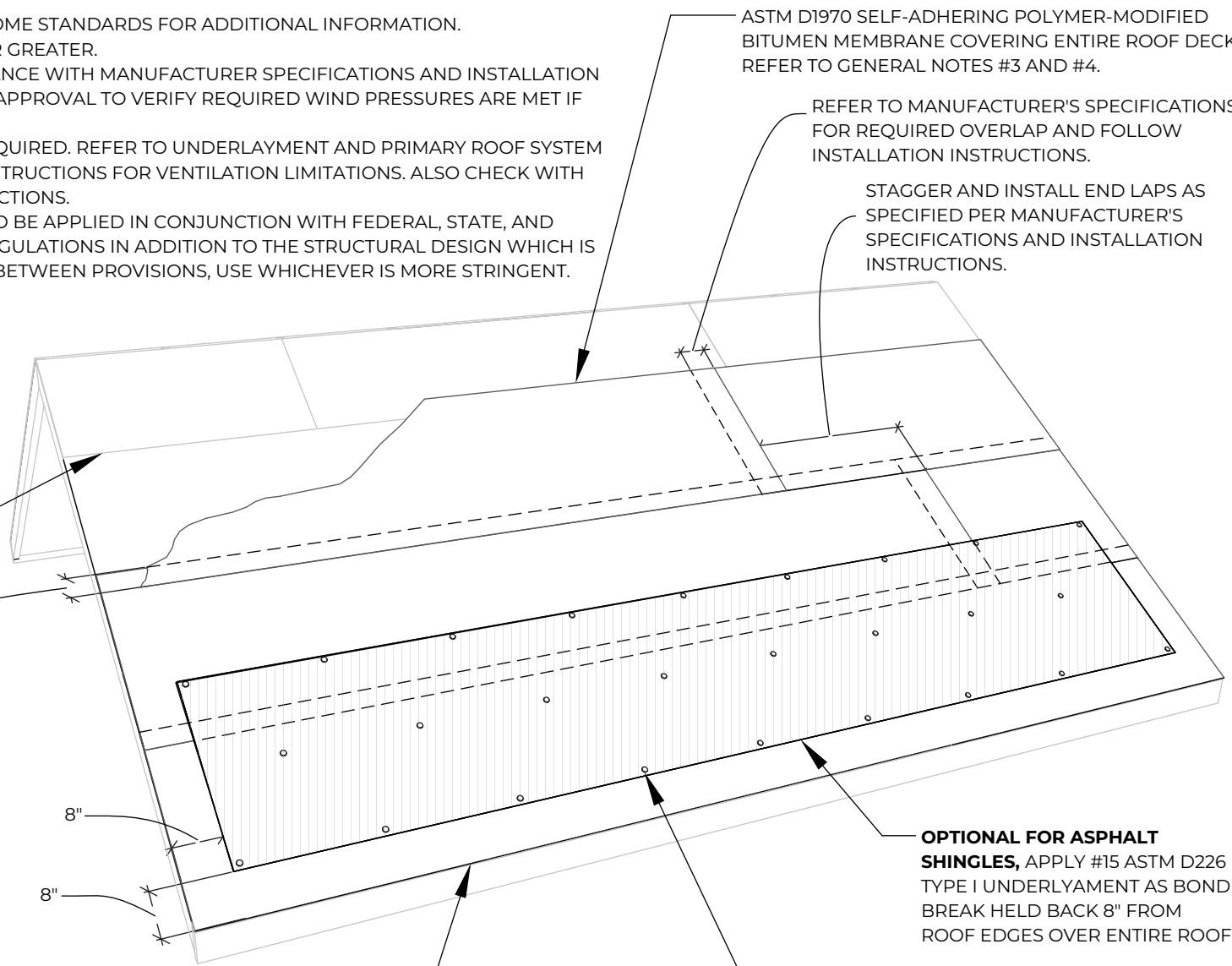

APPLICABLE STANDARDS:

FORTIFIED HOME™ - HURRICANE (2020)
 FORTIFIED HOME™ - HIGH WIND (2020)

DESCRIPTION:

STEEP SLOPE SEALED ROOF DECK - SELF-ADHERED MEMBRANE (SHOWING BOND BREAK FOR ASPHALT SHINGLES) - SHINGLE AND METAL ROOF COVERS

DRAWING #:

F-SRD-4

DATE:

11/01/2020

GENERAL NOTES:

1. REFER TO APPLICABLE FORTIFIED HOME STANDARDS FOR ADDITIONAL INFORMATION.
2. REFER TO FORTIFIED STANDARD DETAIL F-G-1 FOR CORROSION PROTECTION REQUIREMENTS.
3. APPLICABLE FOR ROOF PITCH 2:12 OR GREATER.
4. REFER TO AND INSTALL IN ACCORDANCE WITH MANUFACTURER SPECIFICATIONS AND INSTALLATION INSTRUCTIONS AND FRSA/TRI FLORIDA HIGH WIND TILE INSTALLATION MANUAL REVISED 5TH EDITION (FOR ASCE 7-10) OR 6TH EDITION (FOR ASCE 7-16). REFER TO PRODUCT APPROVAL TO VERIFY REQUIRED WIND PRESSURES ARE MET IF APPLICABLE.
5. ADEQUATE ATTIC VENTILATION IS REQUIRED. REFER TO UNDERLAYMENT AND PRIMARY ROOF SYSTEM MANUFACTURER'S INSTALLATION INSTRUCTIONS FOR VENTILATION LIMITATIONS. ALSO CHECK WITH LOCAL BUILDING CODES FOR RESTRICTIONS.
6. NAILS USED TO ATTACH UNDERLAYMENT SHALL BE ANNULAR RING OR DEFORMED SHANK ROOFING NAILS W/ 0.083" MINIMUM DIAMETER AND SUFFICIENT LENGTH TO PENETRATE THROUGH THE ROOF SHEATHING OR NOT LESS THAN 3/4" INTO THE ROOF SHEATHING W/ 1" DIAMETER BUTTON CAPS (METAL BUTTON CAPS ARE REQUIRED FOR ULTIMATE DESIGN WIND SPEED OF 160 MPH OR GREATER.)
7. FORTIFIED HOME STANDARDS ARE TO BE APPLIED IN CONJUNCTION WITH FEDERAL, STATE, AND LOCAL CODES, ORDINANCES AND REGULATIONS IN ADDITION TO THE STRUCTURAL DESIGN WHICH IS BY OTHERS. IN CASE OF A CONFLICT BETWEEN PROVISIONS, USE WHICHEVER IS MORE STRINGENT.

ROOF SHEATHING 15/32" MIN.; REFER TO FORTIFIED STANDARD DETAILS F-RS-1, F-RS-2, AND F-RS-3.

6" MIN. OVERLAP FOLDED OVER RIDGE ON BOTH SIDES.

4" MIN. (TYP.)

12" O.C. (TYP.)

6" O.C. (TYP.)

6" O.C. (TYP.)

12" O.C. (TYP.)

6" END LAPS (TYP. ALL DIMS)

NOTE: 36" WIDE SHEET SHOWN. FOR WIDER SHEETS, ADDITIONAL ROW(S) OF NAILS WILL BE NEEDED.

TILE CAP SHEET COMPATIBLE WITH TILE ROOF ASSEMBLY: ASTM D1970 SELF-ADHERING POLYMER MODIFIED BITUMEN OR HOT-MOP AN APPROVED TILE UNDERLAYMENT OVER THE ANCHOR SHEET USING ASPHALT IN MANUFACTURER SPECIFICATIONS..

FLASHING TAPE AT ALL PANEL SEAMS FULLY ADHERED W/ NO WRINKLES OR VOIDS USING ROLLER.

MATERIAL OPTION 1: 4" WIDE ASTM D1970 COMPLIANT SELF-ADHERING POLYMER - MODIFIED BITUMEN FLASHING TAPE. **MATERIAL OPTION 2:** 3 - 3/4" WIDE AAMA 711-13 LEVEL 3 (FOR EXPOSURE UP TO 80°C/176°F) COMPLIANT SELF-ADHERING FLASHING TAPE.

ANCHOR SHEET COMPATIBLE WITH TILE ROOF ASSEMBLY: ASTM D226 TYPE II #30 UNDERLAYMENT INSTALLED AS SHOWN OR PER MANUFACTURER SPECIFICATIONS IF MORE STRINGENT.

HOLD BACK BUTTON CAPS AT EDGES TO AVOID INSTALLING DRIP EDGE OVER BUTTON CAPS. DRIP EDGE SHALL BE INSTALLED PER F-DE-1

REFER TO GENERAL NOTE #6. NAILS SPACED AS SHOWN OR A MORE STRINGENT FASTENER SCHEDULE IF REQUIRED BY MANUFACTURER. 6" O.C. ON ALL SIDES AND END LAPS. 12" O.C. MAX. BOTH HORIZONTALLY AND VERTICALLY BETWEEN LAPS.



APPLICABLE STANDARDS:

FORTIFIED HOME™ - HURRICANE (2020)
FORTIFIED HOME™ - HIGH WIND (2020)

DESCRIPTION:

STEEP SLOPE SEALED ROOF DECK - FLASHING TAPE, UNDERLAYMENT AND ROOF TILE CAP SHEET - CONCRETE AND CLAY TILE ROOF COVERS

DRAWING #:

F-SRD-5

DATE:

11/01/2020

GENERAL NOTES:

1. REFER TO APPLICABLE FORTIFIED HOME STANDARDS FOR ADDITIONAL INFORMATION.
2. APPLICABLE FOR ROOF PITCH 2:12 OR GREATER.
3. REFER TO AND INSTALL IN ACCORDANCE WITH MANUFACTURER SPECIFICATIONS AND INSTALLATION INSTRUCTIONS AND FRSA/TRI FLORIDA HIGH WIND TILE INSTALLATION MANUAL REVISED 5TH EDITION (FOR ASCE 7-10) OR 6TH EDITION (FOR ASCE 7-16). REFER TO PRODUCT APPROVAL TO VERIFY REQUIRED WIND PRESSURES ARE MET IF APPLICABLE.
4. ADEQUATE ATTIC VENTILATION IS REQUIRED. REFER TO UNDERLAYMENT AND PRIMARY ROOF SYSTEM MANUFACTURER'S INSTALLATION INSTRUCTIONS FOR VENTILATION LIMITATIONS. ALSO CHECK WITH LOCAL BUILDING CODES FOR RESTRICTIONS.
5. FORTIFIED HOME STANDARDS ARE TO BE APPLIED IN CONJUNCTION WITH FEDERAL, STATE, AND LOCAL CODES, ORDINANCES AND REGULATIONS IN ADDITION TO THE STRUCTURAL DESIGN WHICH IS BY OTHERS. IN CASE OF A CONFLICT BETWEEN PROVISIONS, USE WHICHEVER IS MORE STRINGENT.

ROOF SHEATHING 15/32" MIN ; REFER TO FORTIFIED STANDARD DETAILS F-RS-1, F-RS-2, AND F-RS-3. APPLY MANUFACTURER-SPECIFIED COMPATIBLE PRIMER TO ROOF SHEATHING PER MANUFACTURER INSTALLATION INSTRUCTIONS.

4" MIN. SIDELAPS OR GREATER IF SPECIFIED BY MANUFACTURER'S SPECIFICATIONS AND INSTALLATION INSTRUCTIONS AND FRSA/TRI MANUAL (SEE GENERAL NOTE #3).

ASTM D1970 SELF-ADHERING POLYMER-MODIFIED BITUMEN MEMBRANE (40 MIL MIN. THICKNESS SBS, APP OR APPROVED EQUAL) COMPATIBLE WITH TILE ROOF ASSEMBLY COVERING ENTIRE ROOF DECK. REFER TO GENERAL NOTES #3 AND #4.

REFER TO MANUFACTURER'S SPECIFICATIONS AND FRSA/TRI MANUAL (SEE GENERAL NOTE #3) FOR REQUIRED OVERLAP AND FOLLOW INSTALLATION INSTRUCTIONS.

STAGGER AND INSTALL END LAPS AS SPECIFIED PER FRSA/TRI MANUAL (SEE GENERAL NOTE #3).

DRIP EDGE SHALL BE INSTALLED PER F-DE-1

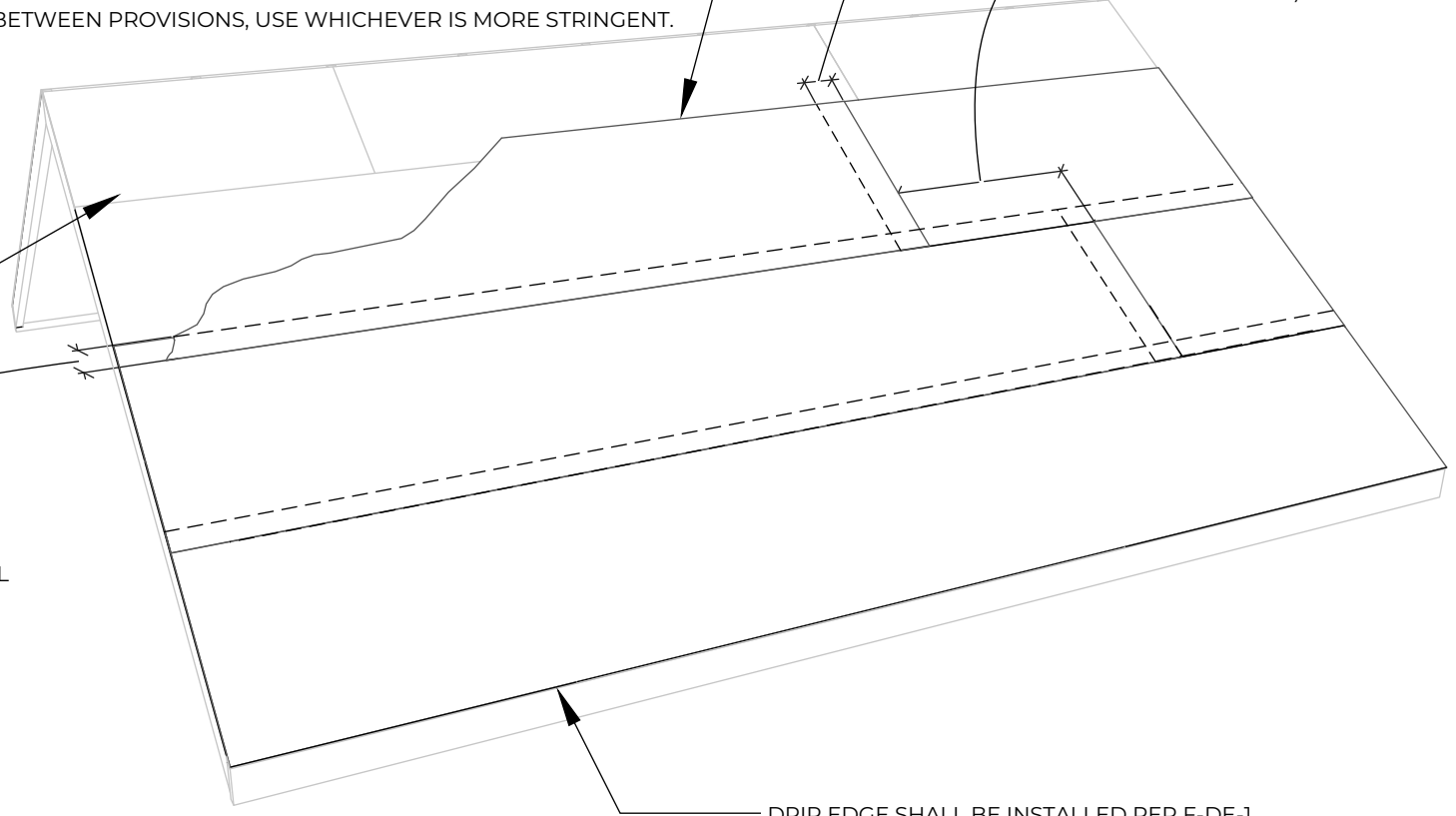

APPLICABLE STANDARDS:

FORTIFIED HOME™ - HURRICANE (2020)
 FORTIFIED HOME™ - HIGH WIND (2020)

DESCRIPTION:

STEEP SLOPE SEALED ROOF DECK - SELF-ADHERED MEMBRANE - CONCRETE AND CLAY TILE ROOF COVERS

DRAWING #:

F-SRD-6

DATE:

11/01/2020

GENERAL NOTES:

1. REFER TO APPLICABLE FORTIFIED HOME STANDARDS FOR ADDITIONAL INFORMATION.
2. REFER TO FORTIFIED STANDARD DETAIL F-G-1 FOR CORROSION PROTECTION REQUIREMENTS.
3. BEST PRACTICES TO SEAL THE DRIP EDGE:
SHINGLE ROOF COVERS: SEAL THE DRIP EDGE, UNDERLAYMENT AND STARTER STRIP AT THE EAVE BY EITHER USING A SELF-ADHERING STARTER STRIP OR APPLYING AN 8" WIDE LAYER OF COMPATIBLE FLASHING CEMENT WITH 1/8" MAX. THICKNESS OVER THE DRIP EDGE AND UNDERLAYMENT.
FOR METAL ROOF COVERS: APPLY A COMPATIBLE MANUFACTURER-APPROVED SEALANT BETWEEN THE DRIP EDGE AND ADJACENT UNDERLAYMENT TO PREVENT WATER FROM ACCUMULATING UNDER THE DRIP EDGE OR USE A MANUFACTURER APPROVED 4" SELF-ADHERED SEAM TAPE.
4. APPLICABLE FOR ROOF PITCH 2:12 OR GREATER. FOR ROOF SLOPES LESS THAN 2:12, REFER TO MANUFACTURER'S DRIP EDGE INSTALLATION REQUIREMENTS.
5. FORTIFIED HOME STANDARDS ARE TO BE APPLIED IN CONJUNCTION WITH FEDERAL, STATE, AND LOCAL CODES, ORDINANCES AND REGULATIONS IN ADDITION TO THE STRUCTURAL DESIGN WHICH IS BY OTHERS. IN CASE OF A CONFLICT BETWEEN PROVISIONS, USE WHICHEVER IS MORE STRINGENT.

METAL DRIP EDGE (MINIMUM 26 GAUGE FOR STEEL) ALONG ALL EAVES AND GABLE RAKE EDGES INSTALLED OVER UNDERLAYMENT. MAKE SURE THE TOP SURFACE OF THE DRIP EDGE IS CLEAN, FREE OF OIL, AND IF REQUIRED BY THE STARTER STRIP MANUFACTURER, PRIMED WITH ASTM D41 PRIMER. FOR SEALING THE DRIP EDGE REFER TO GENERAL NOTE #3.

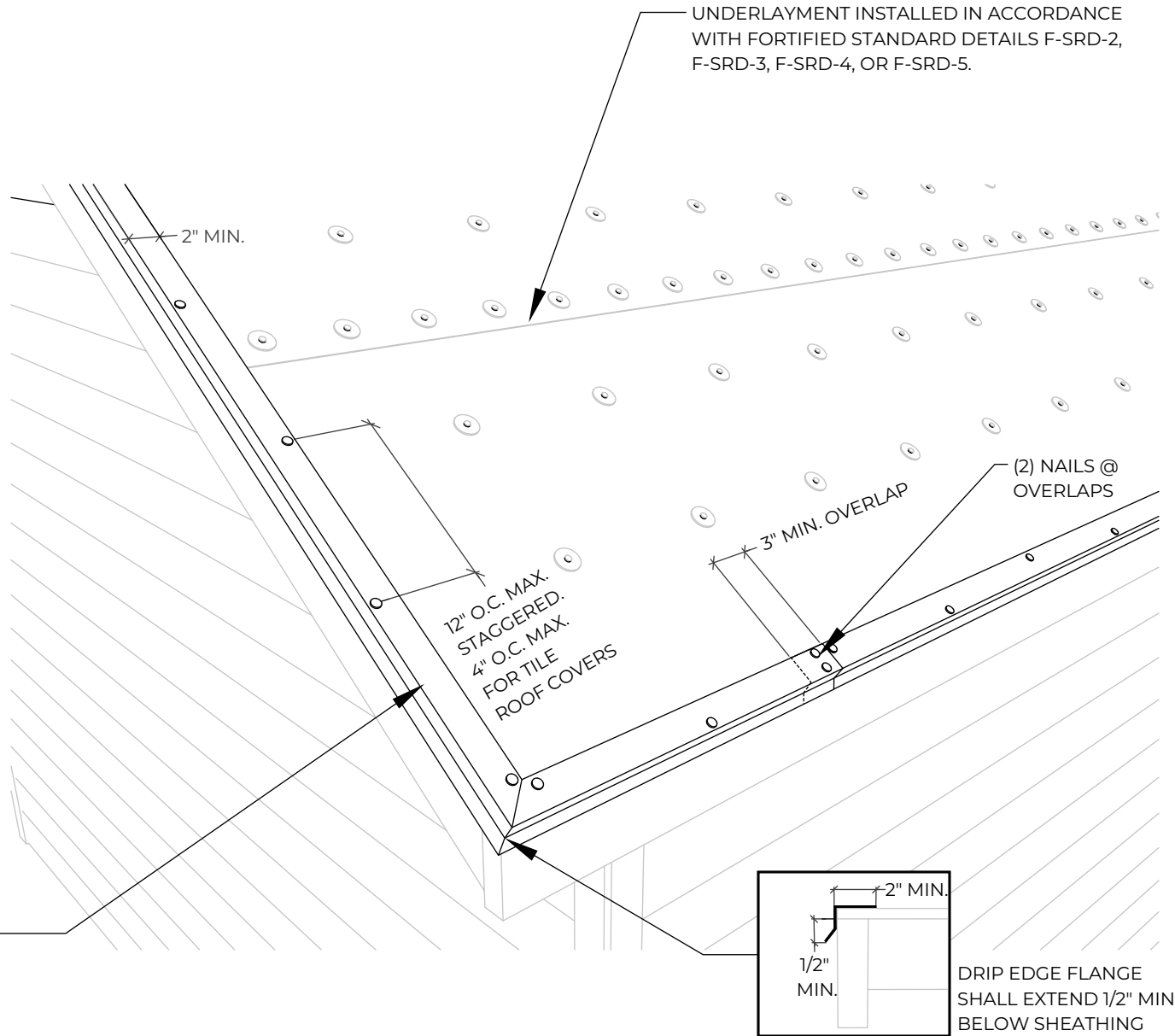

APPLICABLE STANDARDS:
 FORTIFIED HOME™ - HIGH WIND (2020)

DESCRIPTION:
 HIGH WIND - DRIP EDGE
 INSTALLATION OVER
 UNDERLAYMENT

DRAWING #:
 F-DE-3

DATE:
 11/01/2020

GENERAL NOTES:

1. REFER TO APPLICABLE FORTIFIED HOME STANDARDS FOR ADDITIONAL INFORMATION.
2. SHINGLES INSTALLED AT ALL INTERSECTIONS AND BOTH SIDES OF OPEN VALLEYS SHALL BE SET IN A MINIMUM 8 IN. WIDE STRIP OF FLASHING CEMENT (MAX. THICKNESS OF FLASHING CEMENT = 1/8"). CUT SIDE OF CLOSED VALLEYS SHALL BE SET IN A MINIMUM 2 IN. WIDE, 1/8" THICK STRIP OF FLASHING CEMENT. WOVEN VALLEYS TO BE ACCORDING TO THE MANUFACTURER'S SPECIFICATIONS.
3. REFER TO FORTIFIED STANDARD DETAILS F-RC-2 AND F-RC-3 FOR ADDITIONAL ASPHALT SHINGLE INSTALLATION OPTIONS.
4. FORTIFIED HOME STANDARDS ARE TO BE APPLIED IN CONJUNCTION WITH FEDERAL, STATE, AND LOCAL CODES, ORDINANCES AND REGULATIONS IN ADDITION TO THE STRUCTURAL DESIGN WHICH IS BY OTHERS. IN CASE OF A CONFLICT BETWEEN PROVISIONS, USE WHICHEVER IS MORE STRINGENT.

UNDERLAYMENT INSTALLED PER FORTIFIED STANDARD DETAILS F-SRD-2, F-SRD-3, OR F-SRD-4.

SHINGLE MANUFACTURER APPROVED ASTM D1970 FULLY ADHERED STARTER STRIP WITH ASPHALTIC ADHESIVE STRIP AT EAVE.

DRIP EDGE AND ASTM D41 ASPHALT PRIMER INSTALLED PER FORTIFIED STANDARD DETAIL F-DE-1 AND/OR F-DE-3.

STARTER STRIP AND SHINGLES SHALL NOT EXTEND MORE THAN 1/4" BEYOND DRIP EDGE.

ASTM D3161 (CLASS F) OR ASTM D7158 (CLASS H) ASPHALT SHINGLES INSTALLED PER MANUFACTURER RECOMMENDATIONS FOR HIGH WIND REGIONS.

TO MEET 2020 HAIL SUPPLEMENT REQUIREMENTS, ASPHALT SHINGLES MUST HAVE AN OVERALL IBHS ROOF SHINGLE HAIL IMPACT RATING OF "GOOD" OR "EXCELLENT" OR BE POLYMER-MODIFIED WITH EITHER A UL 2218 CLASS 4 OR FM 4473 CLASS 4 RATING.



APPLICABLE STANDARDS:

FORTIFIED HOME™ - HURRICANE (2020)
 FORTIFIED HOME™ - HIGH WIND (2020)

DESCRIPTION:

ASPHALT SHINGLE INSTALLATION GUIDANCE FOR STEEP SLOPE - OPTION 1: PEEL AND STICK STARTER STRIP INSTALLATION AT EAVE OR RAKE

DRAWING #:

F-RC-1

DATE:

11/01/2020

GENERAL NOTES:

1. REFER TO APPLICABLE FORTIFIED HOME STANDARDS FOR ADDITIONAL INFORMATION.
2. SHINGLES INSTALLED AT ALL INTERSECTIONS AND BOTH SIDES OF OPEN VALLEYS SHALL BE SET IN A MINIMUM 8 IN. WIDE STRIP OF FLASHING CEMENT (MAX. THICKNESS OF FLASHING CEMENT = 1/8"). CUT SIDE OF CLOSED VALLEYS SHALL BE SET IN A MINIMUM 2 IN. WIDE, 1/8" THICK STRIP OF FLASHING CEMENT. WOVEN VALLEYS TO BE ACCORDING TO THE MANUFACTURER'S SPECIFICATIONS.
3. REFER TO FORTIFIED STANDARD DETAILS F-RC-1 AND F-RC-3 FOR ADDITIONAL ASPHALT SHINGLE INSTALLATION OPTIONS.
4. FORTIFIED HOME STANDARDS ARE TO BE APPLIED IN CONJUNCTION WITH FEDERAL, STATE, AND LOCAL CODES, ORDINANCES AND REGULATIONS IN ADDITION TO THE STRUCTURAL DESIGN WHICH IS BY OTHERS. IN CASE OF A CONFLICT BETWEEN PROVISIONS, USE WHICHEVER IS MORE STRINGENT.

UNDERLAYMENT INSTALLED PER FORTIFIED STANDARD DETAILS F-SRD-2, F-SRD-3, OR F-SRD-4.

SHINGLE MANUFACTURER APPROVED STARTER STRIP SET IN A MINIMUM 8 IN. WIDE STRIP OF COMPATIBLE FLASHING CEMENT (MAX. THICKNESS OF FLASHING CEMENT = 1/8").

VERIFY WITH MANUFACTURER THAT FLASHING CEMENT/ROOF MASTIC IS COMPATIBLE WITH UNDERLAYMENT.

DRIP EDGE AND ASTM D41 ASPHALT PRIMER INSTALLED PER FORTIFIED STANDARD DETAIL F-DE-1 AND/OR F-DE-3.

STARTER STRIP AND SHINGLES SHALL NOT EXTEND MORE THAN 1/4 IN. BEYOND DRIP EDGE.

ASTM D3161 (CLASS F) OR ASTM D7158 (CLASS H) ASPHALT SHINGLES INSTALLED PER MANUFACTURER RECOMMENDATIONS FOR HIGH WIND REGIONS.

TO MEET 2020 HAIL SUPPLEMENT REQUIREMENTS, ASPHALT SHINGLES MUST HAVE AN OVERALL IBHS ROOF SHINGLE HAIL IMPACT RATING OF "GOOD" OR "EXCELLENT" OR BE POLYMER-MODIFIED WITH EITHER A UL 2218 CLASS 4 OR FM 4473 CLASS 4 RATING.

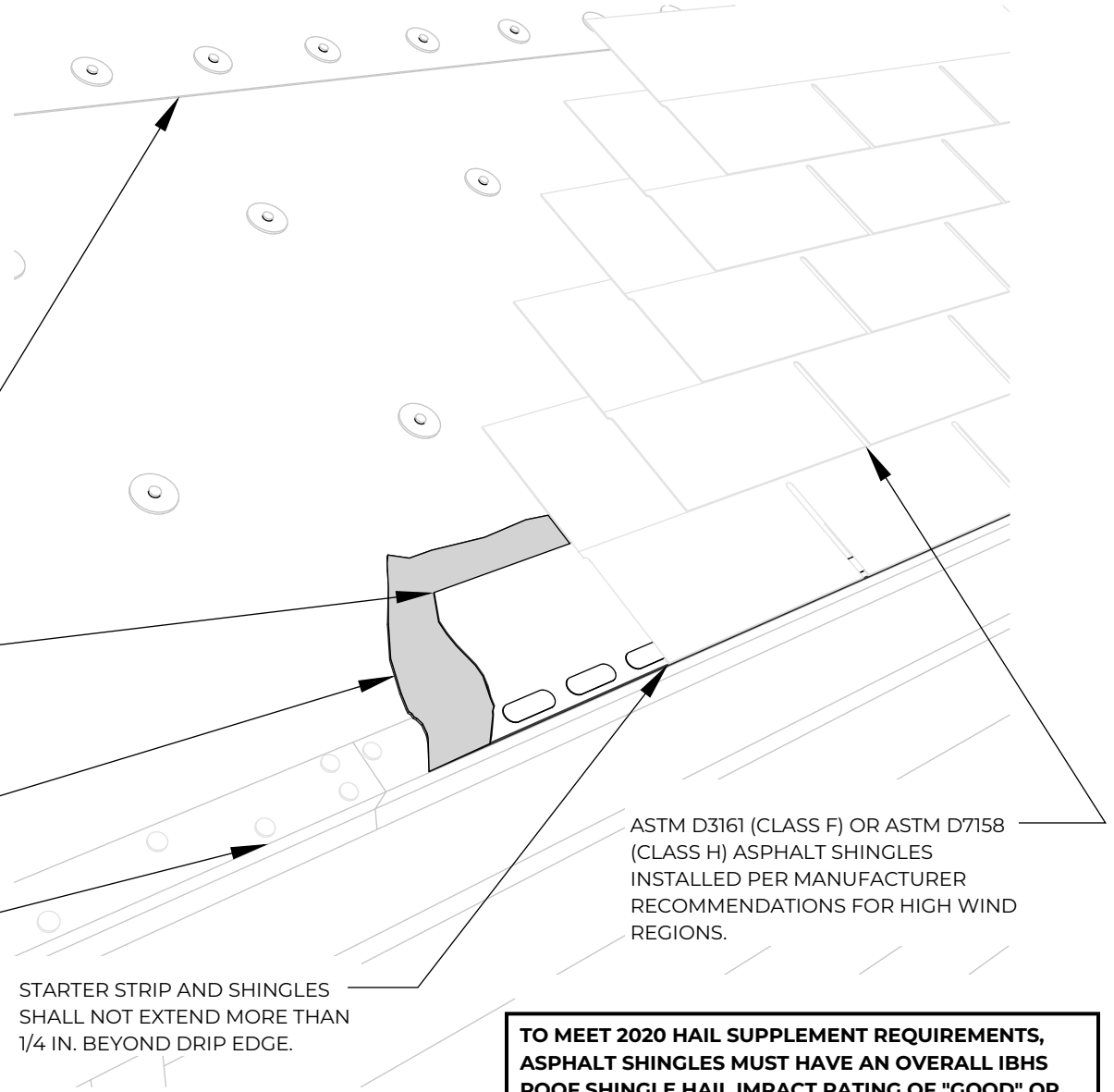

APPLICABLE STANDARDS:

FORTIFIED HOME™ - HURRICANE (2020)
 FORTIFIED HOME™ - HIGH WIND (2020)

DESCRIPTION:

ASPHALT SHINGLE INSTALLATION GUIDANCE FOR STEEP SLOPE - OPTION 2: SHINGLE STRIP STARTER INSTALLATION AT EAVE OR RAKE

DRAWING #:

F-RC-2

DATE:

11/01/2020

GENERAL NOTES:

1. REFER TO APPLICABLE FORTIFIED HOME STANDARDS FOR ADDITIONAL INFORMATION.
2. SHINGLES INSTALLED AT ALL INTERSECTIONS AND BOTH SIDES OF OPEN VALLEYS SHALL BE SET IN A MINIMUM 8 IN. WIDE STRIP OF FLASHING CEMENT (MAX. THICKNESS OF FLASHING CEMENT = 1/8"). CUT SIDE OF CLOSED VALLEYS SHALL BE SET IN A MINIMUM 2 IN. WIDE, 1/8" THICK STRIP OF FLASHING CEMENT. WOVEN VALLEYS TO BE ACCORDING TO THE MANUFACTURER'S SPECIFICATIONS.
3. REFER TO FORTIFIED STANDARD DETAILS F-RC-1 AND F-RC-2 FOR ADDITIONAL ASPHALT SHINGLE INSTALLATION OPTIONS.
4. FORTIFIED HOME STANDARDS ARE TO BE APPLIED IN CONJUNCTION WITH FEDERAL, STATE, AND LOCAL CODES, ORDINANCES AND REGULATIONS IN ADDITION TO THE STRUCTURAL DESIGN WHICH IS BY OTHERS. IN CASE OF A CONFLICT BETWEEN PROVISIONS, USE WHICHEVER IS MORE STRINGENT.

UNDERLAYMENT INSTALLED PER FORTIFIED STANDARD DETAILS F-SRD-2, F-SRD-3, OR F-SRD-4.

DRIP EDGE AND ASTM D41 ASPHALT PRIMER INSTALLED PER FORTIFIED STANDARD DETAIL F-DE-1 AND/OR F-DE-3.

SHINGLES SET DIRECTLY IN A MINIMUM 8 IN. WIDE STRIP OF COMPATIBLE FLASHING CEMENT (MAX. THICKNESS OF FLASHING CEMENT = 1/8"). VERIFY WITH MANUFACTURER THAT FLASHING CEMENT/ROOF MASTIC IS COMPATIBLE WITH UNDERLAYMENT.

ASTM D3161 (CLASS F) OR ASTM D7158 (CLASS H) ASPHALT SHINGLES INSTALLED PER MANUFACTURER RECOMMENDATIONS FOR HIGH WIND REGIONS. SHINGLES SHALL NOT EXTEND MORE THAN 1/4" BEYOND DRIP EDGE.

TO MEET 2020 HAIL SUPPLEMENT REQUIREMENTS, ASPHALT SHINGLES MUST HAVE AN OVERALL IBHS ROOF SHINGLE HAIL IMPACT RATING OF "GOOD" OR "EXCELLENT" OR BE POLYMER-MODIFIED WITH EITHER A UL 2218 CLASS 4 OR FM 4473 CLASS 4 RATING.



| | | | |
|--|--|---|-------------------------|
|  | APPLICABLE STANDARDS: | DESCRIPTION: | DRAWING #: |
| | FORTIFIED HOME™ - HURRICANE (2020) FORTIFIED HOME™ - HIGH WIND (2020) | ASPHALT SHINGLE INSTALLATION GUIDANCE FOR STEEP SLOPE - OPTION 3: SHINGLES SET DIRECTLY IN FLASHING CEMENT AT RAKE ONLY | F-RC-3 |
| | | | DATE: 11/01/2020 |

GENERAL NOTES:

1. REFER TO APPLICABLE FORTIFIED HOME STANDARDS FOR ADDITIONAL INFORMATION.
2. WHEN REPLACING AN ENTIRE DAMAGED SHEET WITH A DIMENSION OF LESS THAN 24" IN ANY DIRECTION, PROVIDE 2X4 BLOCKING ALONG ALL UNSUPPORTED EDGES, AND FASTEN SHEATHING IN ACCORDANCE WITH F-RR-3 AND F-RR-4.
3. FORTIFIED HOME STANDARDS ARE TO BE APPLIED IN CONJUNCTION WITH FEDERAL, STATE, AND LOCAL CODES, ORDINANCES AND REGULATIONS IN ADDITION TO THE STRUCTURAL DESIGN WHICH IS BY OTHERS. IN CASE OF A CONFLICT BETWEEN PROVISIONS, USE WHICHEVER IS MORE STRINGENT.

AT PANEL ENDS, PROVIDE 2 X 4 SCAB FASTENED TO EXISTING MEMBER W/ 16D NAILS @ 4" O.C. STAGGERED, TYP. OF (2).

EXISTING ROOF SHEATHING BY OTHERS W/ 7/16" MIN. THICKNESS AND NO DAMAGE OR DETERIORATION. REFER TO FORTIFIED STANDARD DETAILS F-RR-3 AND F-RR-4 FOR RE-NAILING SCHEDULE.

REFER TO FORTIFIED STANDARD DETAILS F-RR-3 AND F-RR-4 FOR REQUIRED NAILING. ATTACH NEW ROOF DECK TO SCAB (NOT EXISTING ROOF MEMBER), TYP.

PREVIOUSLY DAMAGED ROOF DECK AREA. INSPECT ROOF SUPPORT MEMBERS BELOW FOR DETERIORATION OR DAMAGE AND REPLACE ENTIRE SHEET.

EXISTING ROOF FRAMING MEMBERS W/ 2" MIN. NOMINAL THICKNESS. REFER TO F-RR-2 FOR GUIDANCE ON DETERIORATED OR DAMAGED MEMBERS.

24" O.C. MAX.

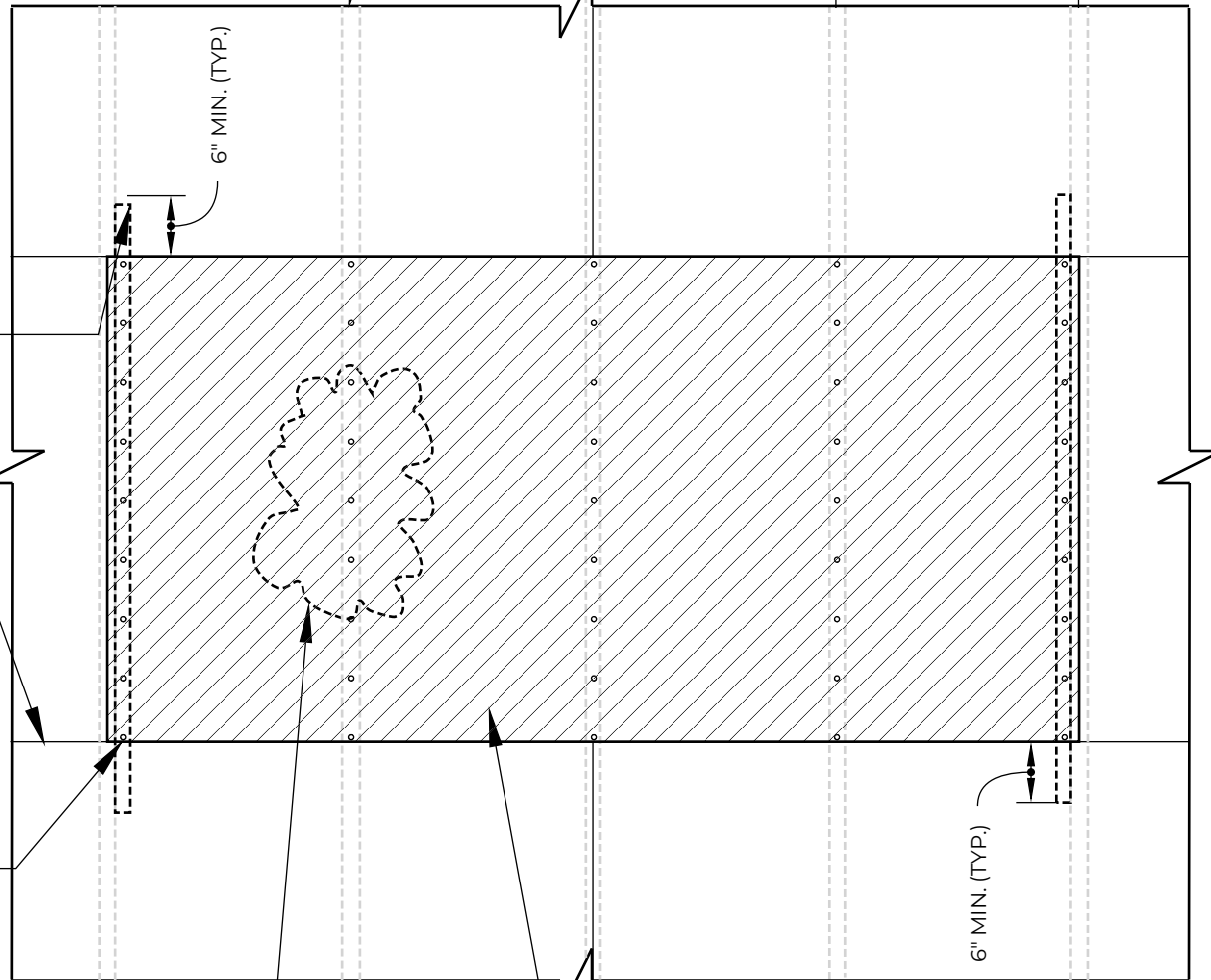

NEW ROOF DECK REPLACEMENT FASTENED TO SCAB, BLOCKINGS (IF APPLICABLE) AND EXISTING FRAMING IN ACCORDANCE WITH FORTIFIED STANDARD DETAILS F-RR-3 AND F-RR-4.



APPLICABLE STANDARDS:

FORTIFIED HOME™ - HURRICANE (2020)
 FORTIFIED HOME™ - HIGH WIND (2020)

DESCRIPTION:

RE-ROOFING DECK REPLACEMENT
 FASTENING DETAIL

DRAWING #:

F-RR-1

DATE:

11/01/2020

GENERAL NOTES:

1. REFER TO APPLICABLE FORTIFIED HOME STANDARDS FOR ADDITIONAL INFORMATION.
2. SCAB WOOD MEMBERS MAY BE TRIMMED UP TO A MAXIMUM OF 1/2" AT THE BOTTOM TO FACILITATE INSTALLATION.
3. IF DAMAGE IS GREATER THAN THE CONDITIONS SHOWN, CONSULT A LICENSED PROFESSIONAL ENGINEER TO PROVIDE ENGINEERING DETAILS TO REPAIR THE DAMAGE.
4. DAMAGED/DETERIORATED AREA MUST BE A MINIMUM OF 6 IN. AWAY FROM ANY MECHANICAL CONNECTIONS (I.E. TRUSS/RAFTER HANGERS, TRUSS CONNECTOR PLATES, ETC.)
5. WHEN THE FASCIA OR SUB-FASCIA IS THE ROOF FRAMING MEMBER THAT IS DAMAGED OR DETERIORATED, REMOVE AND REPLACE THE DAMAGED/DETERIORATED SECTION PLUS AT LEAST 2 FT. BEYOND THAT SECTION ON EACH SIDE.
6. FORTIFIED HOME STANDARDS ARE TO BE APPLIED IN CONJUNCTION WITH FEDERAL, STATE, AND LOCAL CODES, ORDINANCES AND REGULATIONS IN ADDITION TO THE STRUCTURAL DESIGN WHICH IS BY OTHERS. IN CASE OF A CONFLICT BETWEEN PROVISIONS, USE WHICHEVER IS MORE STRINGENT.

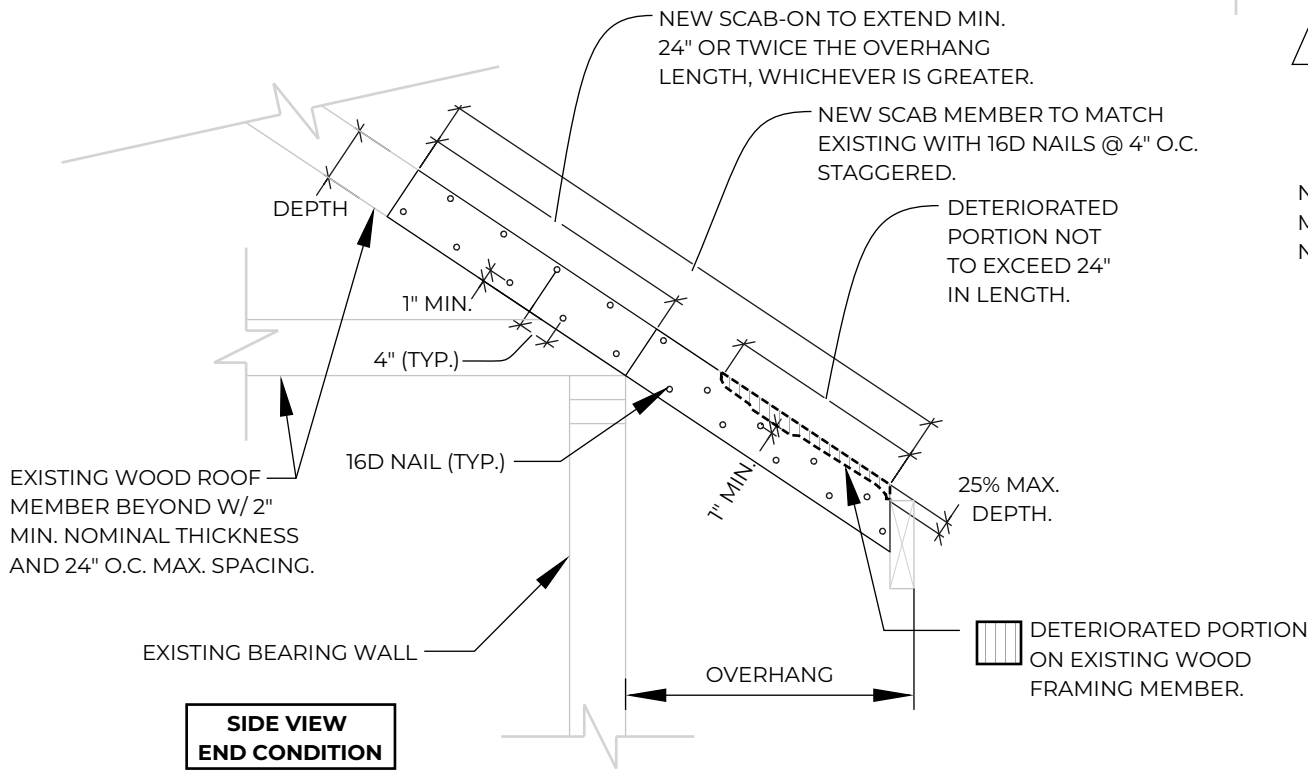

**SIDE VIEW
END CONDITION**

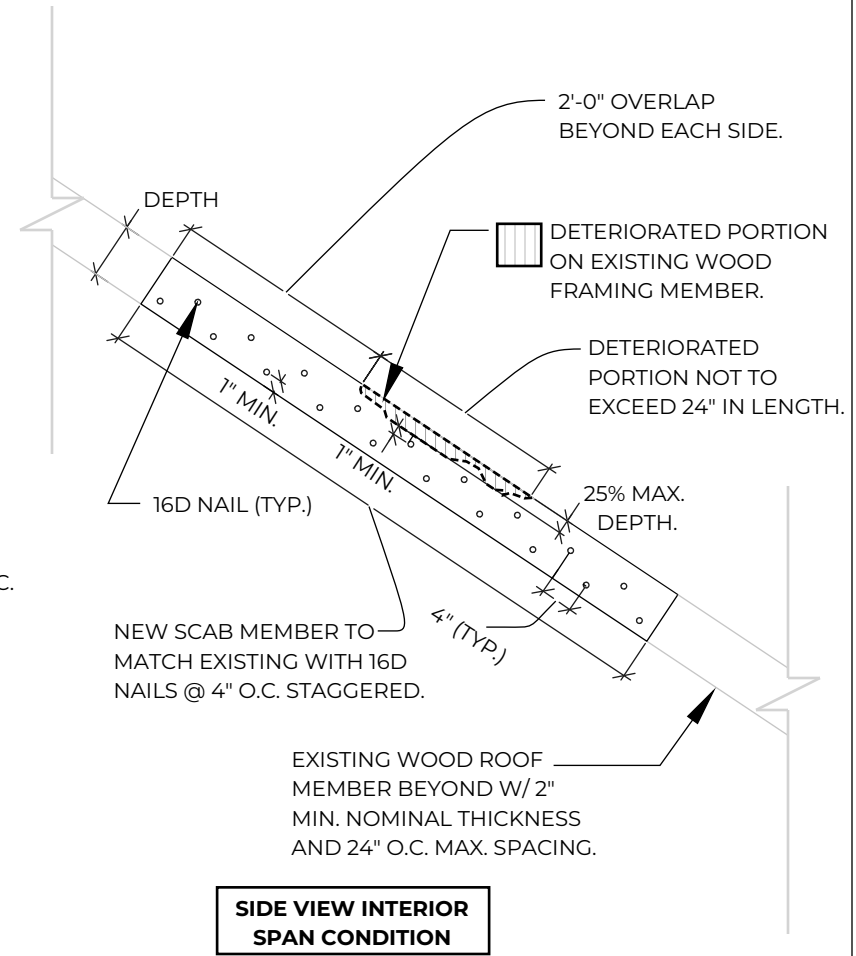

**SIDE VIEW INTERIOR
SPAN CONDITION**

| | | | |
|--|--|---|-------------------------|
|  | APPLICABLE STANDARDS: | DESCRIPTION: | DRAWING #: |
| | FORTIFIED HOME™ - HURRICANE (2020) FORTIFIED HOME™ - HIGH WIND (2020) | RE-ROOFING NEW SCAB MEMBER DETAIL FOR DAMAGED OR DETERIORATED WOOD FRAMING MEMBER | F-RR-2 |
| | | | DATE: 11/01/2020 |

GENERAL NOTES:

1. REFER TO APPLICABLE FORTIFIED HOME STANDARDS FOR ADDITIONAL INFORMATION.
2. REFER TO F-RS-3 FOR MINIMUM SHEATHING THICKNESS REQUIREMENTS.
3. FORTIFIED HOME STANDARDS ARE TO BE APPLIED IN CONJUNCTION WITH FEDERAL, STATE, AND LOCAL CODES, ORDINANCES AND REGULATIONS IN ADDITION TO THE STRUCTURAL DESIGN WHICH IS BY OTHERS. IN CASE OF A CONFLICT BETWEEN PROVISIONS, USE WHICHEVER IS MORE STRINGENT.

EXISTING ROOF FRAMING MEMBERS W/ 2" MIN. NOMINAL THICKNESS. REFER TO F-RR-2 FOR GUIDANCE ON DETERIORATED OR DAMAGED MEMBERS.

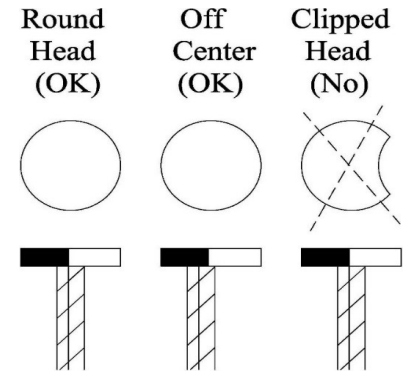
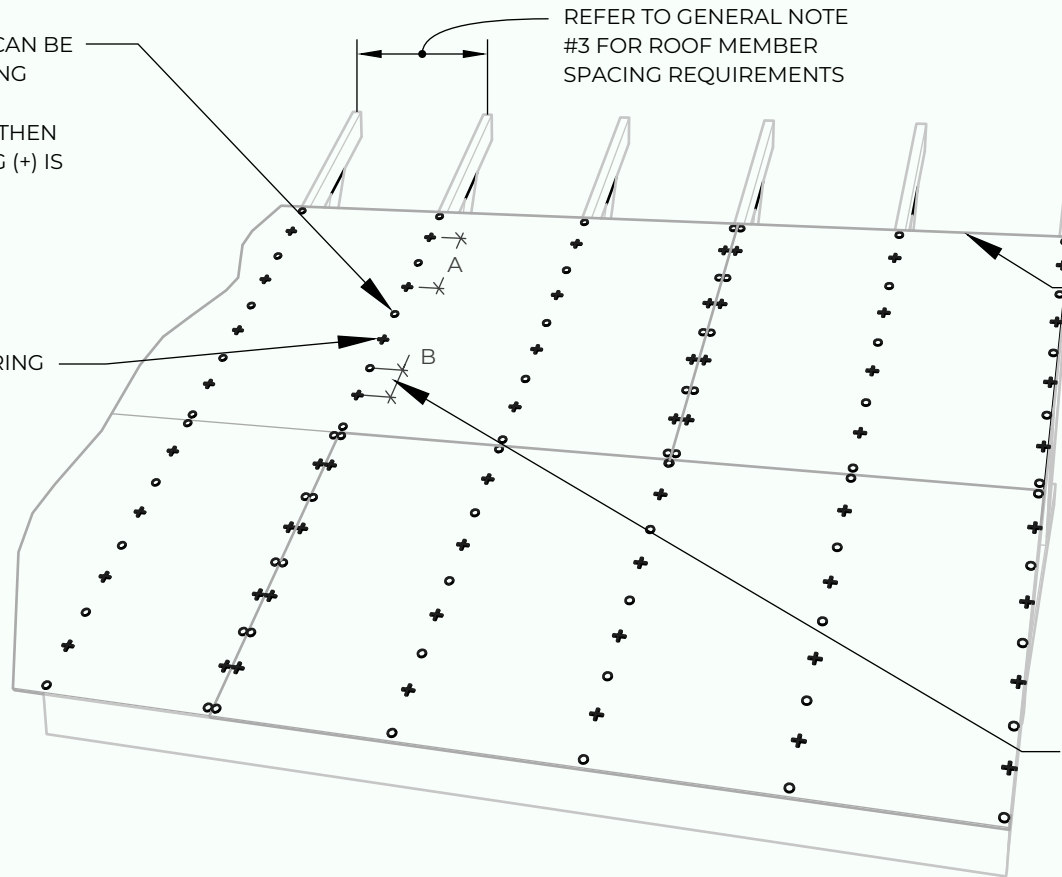

FIGURE 1.

○ EXISTING FASTENERS; IF IT CAN BE DOCUMENTED THAT EXISTING NAILING MEETS THE REQUIREMENTS OF F-RS-3, THEN SUPPLEMENTAL FASTENING (+) IS NOT REQUIRED.

+ ADDITIONAL 0.113" X 2-3/8" 8D RING SHANK NAILS @ = 6" O.C.



REFER TO GENERAL NOTE #3 FOR ROOF MEMBER SPACING REQUIREMENTS

EXISTING STRUCTURAL WOOD PANEL ROOF SHEATHING (PLYWOOD OR OSB) BY OTHERS W/ NO DAMAGE OR DETERIORATION. REFER TO F-RR-1 FOR DAMAGED OR DETERIORATED SHEATHING. REFER TO F-RS-3 FOR SHEATHING THICKNESS REQUIREMENTS.

B: TO AVOID WOOD SPLITTING, SPACING BETWEEN NEW AND EXISTING NAILS "B" SHALL NOT BE LESS THAN 2 IN. NAILS SHALL BE STAGGERED WHEN "B" IS LESS THAN OR EQUAL TO 3 IN.

KEY:

- = EXISTING FASTENERS
- + = ADDITIONAL FASTENERS
- A = SPACING OF ADDITIONAL FASTENERS
- B = SPACING BETWEEN EXISTING AND ADDITIONAL FASTENER



APPLICABLE STANDARDS:
FORTIFIED HOME™ - HIGH WIND (2020)

DESCRIPTION:

HIGH WIND - RE-NAILING THE ROOF DECK (WOOD STRUCTURAL PANELS)

DRAWING #:

F-RR-4

DATE:

11/01/2020

GENERAL NOTES:

1. REFER TO APPLICABLE FORTIFIED HOME STANDARDS FOR ADDITIONAL INFORMATION.
2. APPLICABLE FOR ROOF PITCH 2:12 OR GREATER.
3. LOCAL BUILDING CODE REQUIREMENTS FOR ROOF SHEATHING THICKNESS AND/OR NAIL SIZE/ATTACHMENT SPACING MAY BE MORE STRINGENT BASED ON SITE CONDITIONS.
4. FOR CONCRETE AND CLAY TILE ROOF COVERS, MINIMUM REQUIRED SHEATHING THICKNESS IS 15/32".
5. FULL ROUND HEAD DIAMETER; NO CLIPPED-HEAD NAILS, COMMON NAILS OR STAPLES SHALL BE ALLOWED. REFER TO FIGURE 1.
6. FORTIFIED HOME STANDARDS ARE TO BE APPLIED IN CONJUNCTION WITH FEDERAL, STATE, AND LOCAL CODES, ORDINANCES AND REGULATIONS IN ADDITION TO THE STRUCTURAL DESIGN WHICH IS BY OTHERS. IN CASE OF A CONFLICT BETWEEN PROVISIONS, USE WHICHEVER IS MORE STRINGENT.

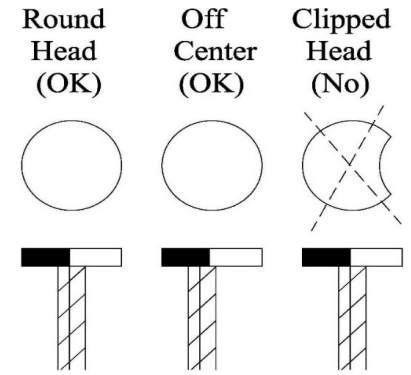
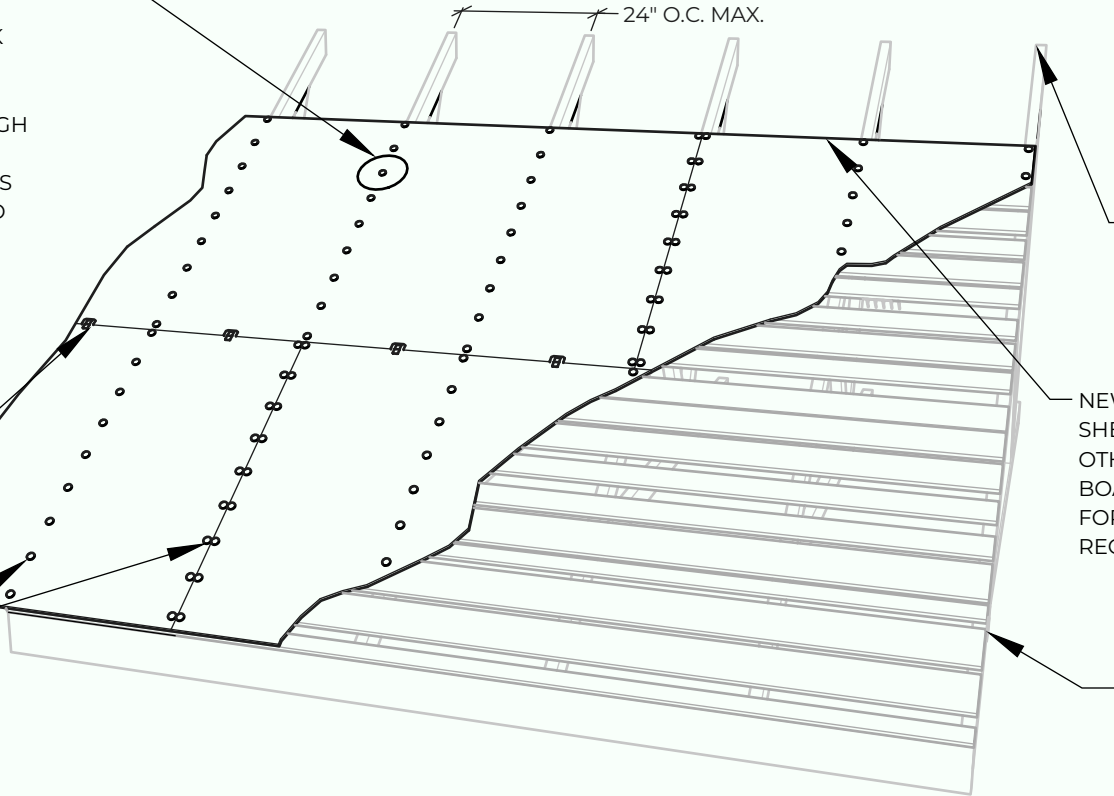

FIGURE 1.

RSRS-04 (0.120" DIA. X 3" MIN.) OR
RSRS-05 (0.131" DIA. X 3" MIN.)
ROOF SHEATHING RING SHANK
NAILS @ 4" O.C. INTO ROOF
FRAMING MEMBERS. NAIL
LENGTH MUST BE LONG ENOUGH
TO ENSURE 1-5/8" EMBEDMENT
INTO ROOF FRAMING MEMBERS
THROUGH PLYWOOD/OSB AND
EXISTING DECK BOARDS.
ALT: #8 X 3" MIN. LONG WOOD
SCREWS @ 6" O.C.

PANEL
CLIPS BY
OTHERS.



ROOF FRAMING MEMBERS
W/ 2" MIN. NOMINAL THICKNESS.

NEW STRUCTURAL WOOD PANEL ROOF
SHEATHING (PLYWOOD OR OSB) BY
OTHERS INSTALLED OVER EXISTING DECK
BOARDS. REFER TO F-RS-2 AND/OR F-RS-3
FOR SHEATHING THICKNESS
REQUIREMENTS (MIN. 7/16").

EXISTING ROOF DECK BOARDS
WITH GAPS GREATER THAN 1/8"

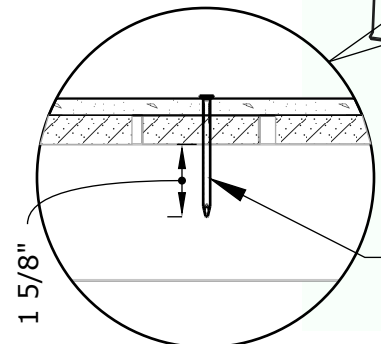

FASTENERS 4 IN. O.C.
PENETRATING WOOD
FRAMING MIN. 1 - 5/8".



APPLICABLE STANDARDS:

FORTIFIED HOME™ - HURRICANE (2020)
FORTIFIED HOME™ - HIGH WIND (2020)

DESCRIPTION:

FASTENING WOOD STRUCTURAL
PANEL ROOF SHEATHING OVER
EXISTING 1X ROOF DECK BOARDS
WITH GAPS

DRAWING #:

F-RR-5

DATE:

11/01/2020

- GENERAL NOTES:**
- REFER TO APPLICABLE FORTIFIED HOME STANDARDS FOR ADDITIONAL INFORMATION.
 - PRESCRIPTIVE RETROFIT GUIDANCE IS APPLICABLE FOR CHIMNEYS LOCATED IN THE INTERIOR ZONE OF THE ROOF (ZONE 1) AND EXTENDING LESS THAN 5 FT ABOVE THE ROOF DECK. ANCHORAGE FOR CHIMNEYS OUTSIDE OF THESE LIMITATIONS REQUIRES ENGINEERING REVIEW AND DETAILING BY A PROFESSIONAL ENGINEER.
 - FORTIFIED HOME STANDARDS ARE TO BE APPLIED IN CONJUNCTION WITH FEDERAL, STATE, AND LOCAL CODES, ORDINANCES AND REGULATIONS IN ADDITION TO THE STRUCTURAL DESIGN WHICH IS BY OTHERS. IN CASE OF A CONFLICT BETWEEN PROVISIONS, USE WHICHEVER IS MORE STRINGENT.

EXTERIOR FULLY SHEATHED WITH 7/16" MIN. WOOD STRUCTURAL PANELS.

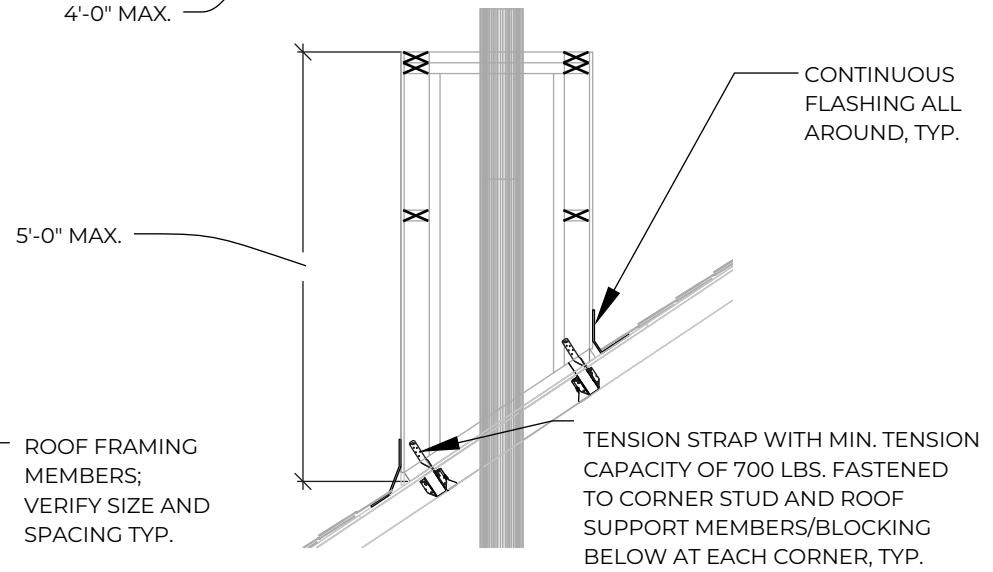
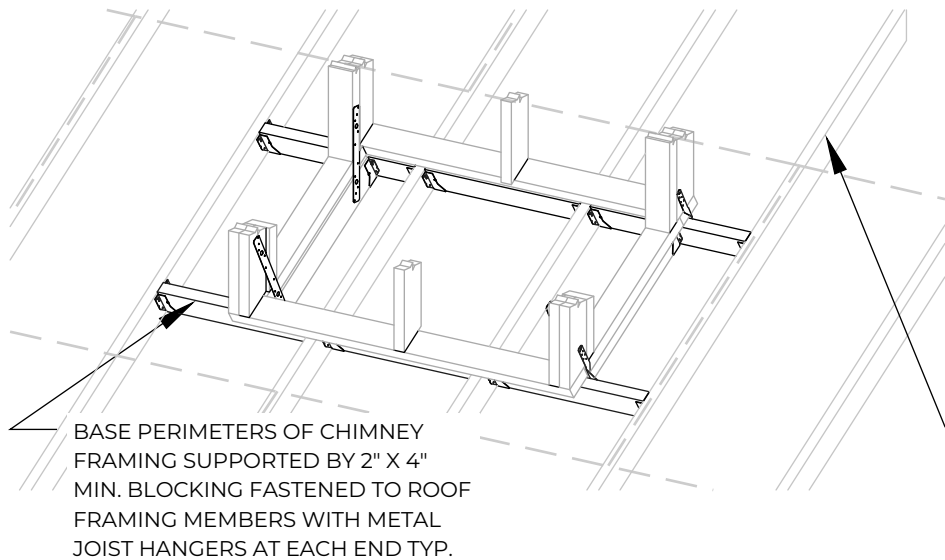
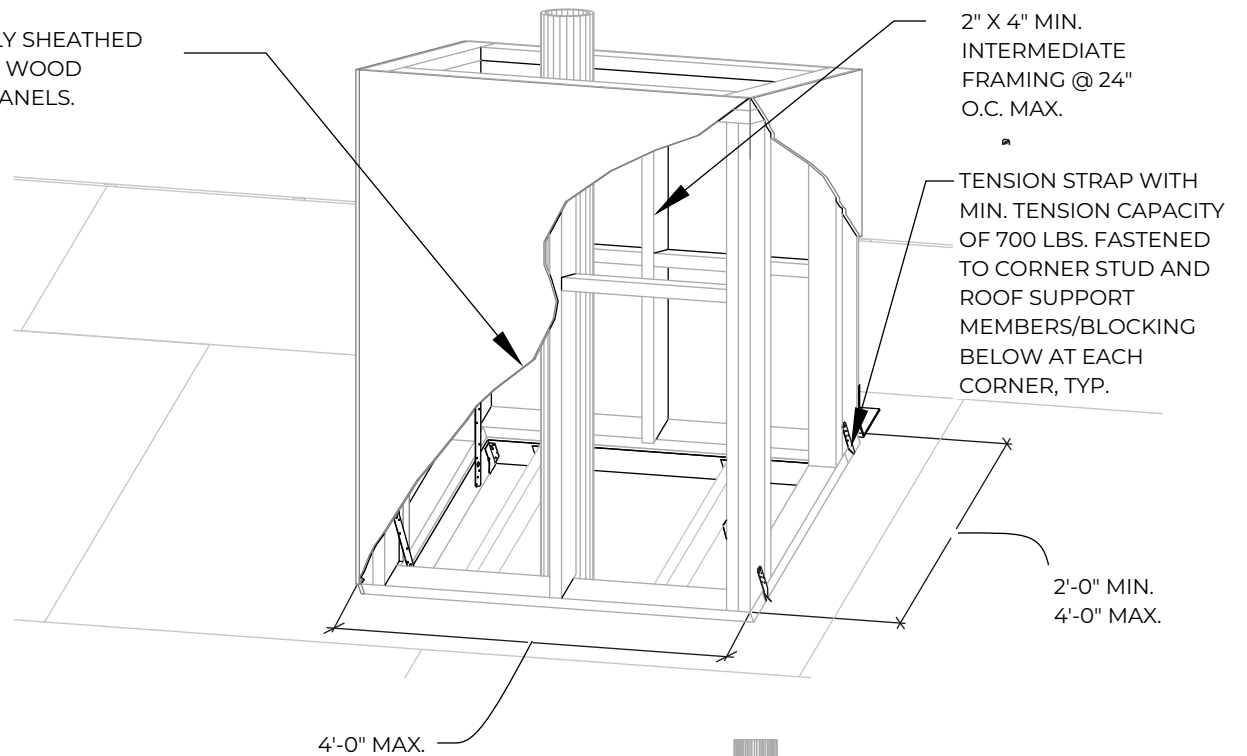

| | | | |
|--|--|---|-----------------------|
|  | APPLICABLE STANDARDS: | DESCRIPTION: | DRAWING #: |
| | FORTIFIED HOME™ - HURRICANE (2020) FORTIFIED HOME™ - HIGH WIND (2020) | PRESCRIPTIVE CHIMNEY TIE-DOWN DETAIL FOR CHIMNEYS UP TO 5 FT | F-CTD-1 |
| | | | DATE: 11/01/20 |